

**Brymec** 

**Brymec Copper Press Gas  
Technical Manual 2023**





# Contents

<b>Introduction to Brymec</b>	4
<b>Environmental Model</b>	5
<b>Brymec Copper Press Gas System Introduction</b>	6
<b>Key Features and Advantages</b>	8
<b>Technical Information</b>	
Certification and Applications	10
Corrosion and Expansion	12
Installation Design Considerations	16
Spacing Requirements	17
Support Centres	18
Brazing near Fittings	19
Compatible Tooling	20
Testing Procedures	22
Flushing	24
<b>Product Range</b>	25
<b>Installation</b>	
Installation Procedure	32
Brymec Training Programme	34
Brymec Technical Support	35
<b>Warranty</b>	36
<b>General Information</b>	38





# ➤ Introducing Brymec

Our philosophy has always been to provide the ultimate convenience and peace of mind to our clients. This also includes ensuring that you have the best possible products to select from.

By investing in innovation, we have been able to engineer our own range of products, all manufactured to our exacting specifications to deliver quality solutions for the Building Services Industry.

Every one of our Brymec products is manufactured to the highest quality standards possible and are backed up by our in-house technical support, robust quality controls and industry-leading guarantees.

Our innovative approach simplifies your supply chain, giving you direct access to the manufacturer. This gives you greater control and confidence in Brymec being the right partner for you.

With almost 50 years of experience, we understand the challenges you face and the solutions you require.

This complete understanding of industry products and systems enable us to collaborate with you more effectively and efficiently, to deliver a more comprehensive range of products that are specific to your needs.



## ➤ Our 3 Step Approach to an Environmentally Friendly Build...

Brymec cuts down the movement of products, which cuts the impact to the environment

This helps our customers reduce their carbon footprint of the products they buy from us

### Traditional Model

- |                                 |                         |                     |
|---------------------------------|-------------------------|---------------------|
| ➊ Manufacturer                  | ➋ European Distribution | ➌ UK Distribution   |
| ➍ Merchant Central Distribution | ➎ Branches              | ➏ Construction Site |

### Our Environmentally Friendly Business Model





# ➤ Brymec Copper Press Gas System

The use of Press Fit for a quicker and improved method for pipework connection started over 50 years ago and has greatly increased to assist the industry to reduce time, cost and carbon footprint. There have been further developments over the year such as the addition of Stainless Steel ranges.

## Benefits of Brymec Press Fit – the Five S's

There are many benefits in using Brymec Copper Press Gas connections for a quick and permanent joint:

- **Speed** of installation
- **Simplicity** of planning and installing a project
- **Safety** – no risk of fire, fire risk or fire watch times
- **Solder Free** – no need for consumables such as Solder, Flux, Brazing Rods, heat mats, rags, gas
- **Savings** due to efficiency

We have used our knowledge of what Engineers, Designers and Installers require to make sure that the Brymec Copper Press Gas system has the unique features that will make a difference to your project.

The Copper Press Gas System is an important part of the full range on Brymec Press Fit Products, which includes Press Fit for water applications and Stainless Press Fit in all sizes from 15mm up to 108mm.

This tried and proven range has been engineered utilising our many years of product excellence and design to provide utmost confidence in the quality, security and ease of install with our system.

As well as market leading Quality Control and ability to deliver a project in a way that reduces time and cost, we have several unique features which give ultimate satisfaction. Our track record of successful projects range from vital fast track projects to use on some of the most prestigious buildings in the UK, and are evidence that Brymec Copper Press Gas is the product of choice.





# ➤ Key Features and Advantages

The Brymec Copper Press Gas System has several key advantages including unique products and designs.

With our product the combination of features and unique details is designed to provide the user with the easiest and most reliable installation. This is coupled with best practice standards from the start of manufacture to the completion of a project.

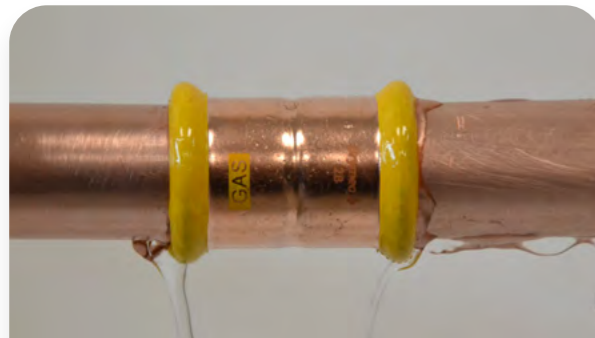

## 100% RELIABLE LEAK PATH DETECTION

This feature allows a fitting to have a slight leak that is visible under initial pressure to clearly identify if the fitting has not been crimped. The uniquely designed HNBR O-ring allows the medium to seep past the seal prior to being crimped. Once crimped a leak proof seal is created.

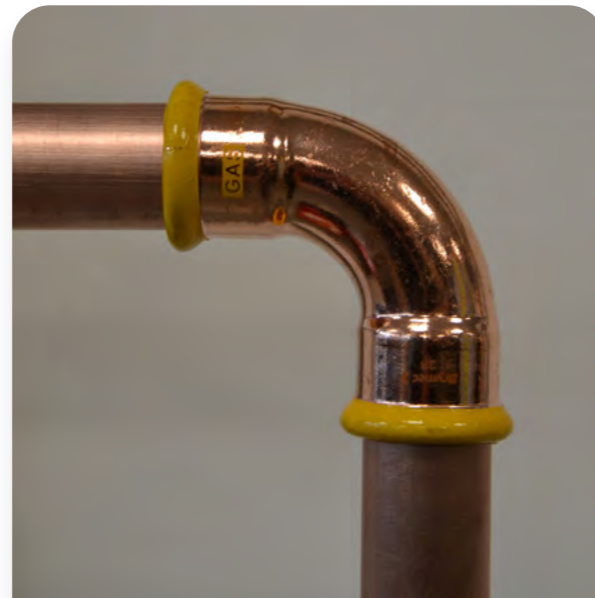

## VISUAL CRIMP INDICATOR

The visual crimp indicator provides a clear visual confirmation if a fitting has been crimped or not. Each gasket housing has a yellow indicator ring which peels off once the fitting has been crimped.



## FRICITION FIT FOR EASE OF INSTALLATION

Our unique fitting design removes the need to support loosely fitting pipe and fittings during the installation process or else having to crimp each fitting as you go. Fittings can be dry fitted to create your pipework layouts and will hold position greatly speeding up the installation process.



## O-RING PROTECTOR

Each press fitting is equipped with plastic O-ring protectors, which are fixed in place during production. This means that the HNBR O-Ring is protected from the moment it is manufactured to the point of delivery on site. The O-ring protector helps keep the O-Rings protected from dust, grease and other impurities, and removes the risk of damage or contamination in transit. The covers also have the fitting size clearly embossed to aid identification.

# Technical Information

## ➤ Technical Data & Applications

Application	Comment	Pressure	Temp. (°C)
Natural Gas Installations	Above Ground 2nd Family Gases to EN437	1 bar indoors 5 bar outdoors	-20-70
LPG, Liquefied petroleum gas installations	Above Ground 3rd Family Gases to EN437	1 bar indoors 5 bar outdoors	-20-70

Our copper gas fittings are made from Copper Cu-DHP (CW024A) with a Hydrogenated Nitrile Butadiene Rubber (HNBR) O ring suitable for an operating temperature range of -20 to 70°C.



# Design Considerations

## Corrosion

### External Corrosion Resistance:

Protection against external corrosion is not usually required due to the inherent properties of copper. However if the surroundings of copper tube and Brymec Copper Press Gas fittings contain nitrates, ammonia or sulphides external protection is necessary. For example if copper pipes are laid beneath a screed or plaster, some form of external protection must be used. This could be in the form of a plastic protective coating or other suitable impervious layer.

## Linear Pipe Expansion

Changes in temperature cause pipework systems to expand and contract to different degrees depending on the temperature and material differences. It is of key importance that this thermal movement is considered when designing and installing pipework systems. Fixing pipework too rigidly, can restrict the natural expansion that comes from thermal fluctuations, causing mechanical stress and tension and compromise the integrity of joints.

The heat expansion co-efficient of copper can be calculated with the below formula:

$$\Delta L = L * \alpha * \Delta T$$

### Whereby:

$\Delta L$  = total extension in mm. L = length of the pipe in m.

$\Delta T$  = Temperature fluctuation in °K.

$\alpha$  = Linear expansion coefficient ( $\alpha = 0.0166$  mm/m for Copper pipe).

The following table can be used to calculate the thermal extension of copper:

Change in Length $\Delta L$ (mm) for copper with temperature difference $\Delta t$ °C										
Pipe Length (m)	$\Delta t=10^\circ$	$\Delta t=20^\circ$	$\Delta t=30^\circ$	$\Delta t=40^\circ$	$\Delta t=50^\circ$	$\Delta t=60^\circ$	$\Delta t=70^\circ$	$\Delta t=80^\circ$	$\Delta t=90^\circ$	$\Delta t=100^\circ$
1	0.17	0.33	0.50	0.66	0.83	1.00	1.16	1.33	1.49	1.66
2	0.33	0.66	1.00	1.33	1.66	1.99	2.32	2.66	2.99	3.32
3	0.50	1.00	1.49	1.99	2.49	2.99	3.49	3.98	4.48	4.98
4	0.66	1.33	1.99	2.66	3.32	3.98	4.65	5.31	5.98	6.64
5	0.83	1.66	2.49	3.32	4.15	4.98	5.81	6.64	7.47	8.30
6	1.00	1.99	2.99	3.98	4.98	5.98	6.97	7.97	8.96	9.96
7	1.16	2.32	3.49	4.65	5.81	6.97	8.13	9.30	10.46	11.62
8	1.33	2.66	3.98	5.31	6.64	7.97	9.30	10.62	11.95	13.28
9	1.49	2.99	4.48	5.98	7.47	8.96	10.46	11.95	13.45	14.94
10	1.66	3.32	4.98	6.64	8.30	9.96	11.62	13.28	14.94	16.60
15	2.49	4.98	7.74	9.96	12.45	14.94	17.43	19.92	22.41	24.90
20	3.32	6.64	9.96	13.28	16.60	19.92	23.24	26.56	29.88	33.20



## The basic principle is that there must always be adequate capacity for expansion between two fixed points.

The inherent elasticity of the pipework can often be used to compensate for expansion, however wherever there is a change in pipework direction it is necessary to arrange pipe clamps to provide sufficiently flexible pipe limbs.

If the pipework installation is buried or concealed, it is important that thermal expansion is not impeded, by encapsulating the pipes with elastic chloride-free material of sufficient thickness

If sufficient compensation for thermal expansion is not accommodated within the natural pipe routing the following measures can be taken:

- Expansion equalization joints (expansion bends)
- Fixed and Sliding points
- Expansion compensators

### Expansion equalization Joints

There are three types of expansion equalization joints that can be used. These are U-shaped, Z-shaped or T-shaped. The formula for which these are calculated is as follows:

$$L_b = k \times \sqrt{(OD \times \Delta l)}$$

- $L_b$  = expansion compensation length (mm)
- $k$  = material constant - 0.0166 mm/m
- $OD$  = outside diameter of the tube (mm)
- $\Delta l$  = linear expansion that needs to be compensated (mm)

Z-Shaped or T-Shaped equalization joints:

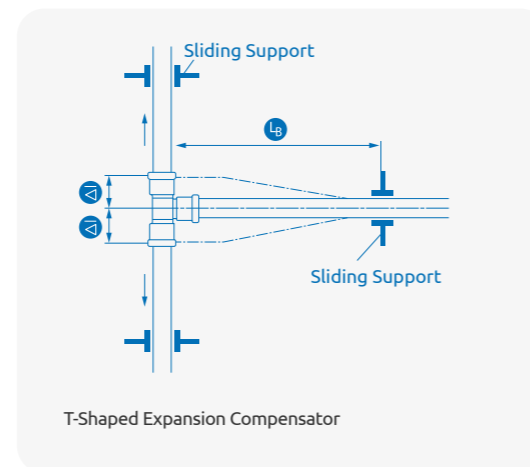
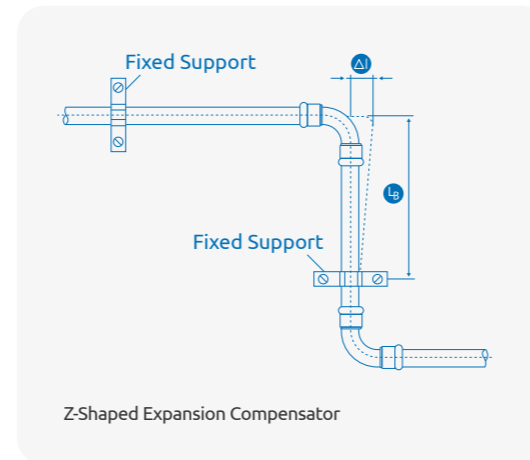
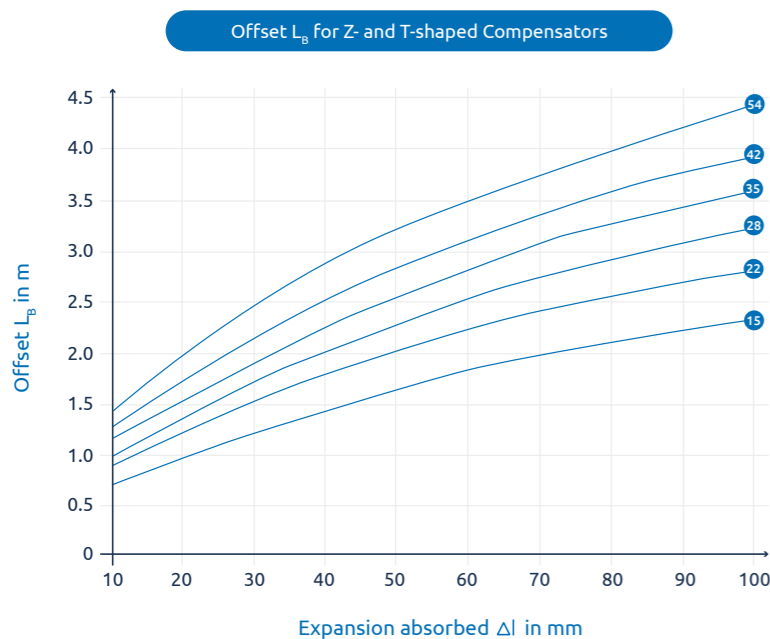

### U-Shaped Equalization Joints:

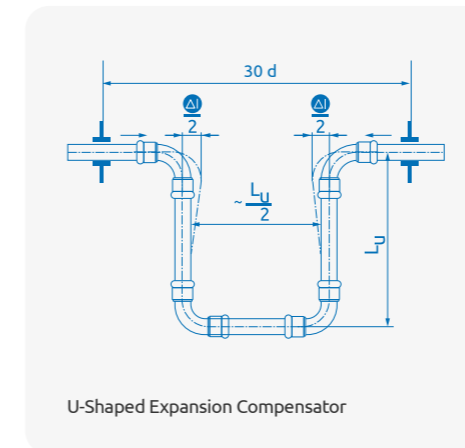

### Formula

$$L_U = 0.032 \cdot \sqrt{OD \cdot \Delta l} \text{ (m)}$$

( $OD$  and  $\Delta l$  in mm)

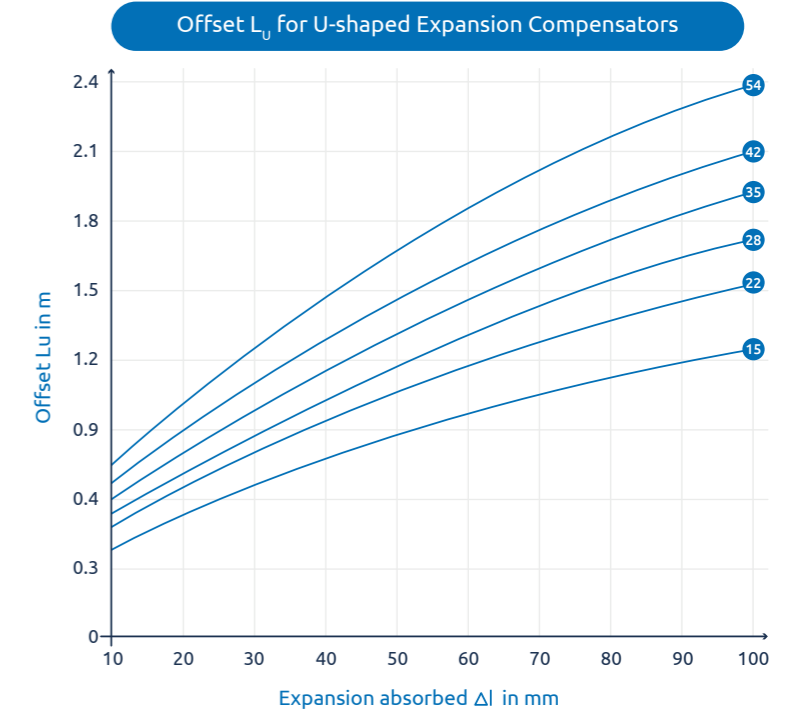

### Commercial Axial Expansion Compensator:

When space is limited, the axial compensator provides a solution for expansion and contraction. It is an expansion joint with a corrugated bellow that allows movement, and well as dampening vibrations and reducing noise.

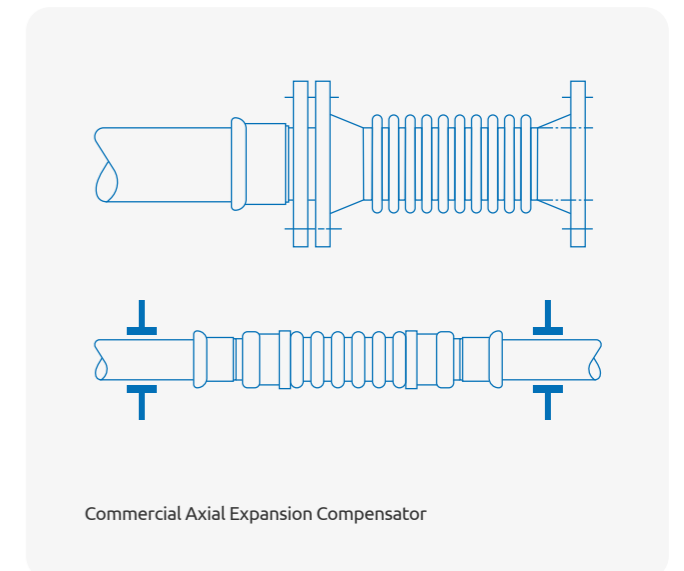



# Installation Design Considerations

A minimum separation between fitting installation needs to occur to ensure the press forming does not possibly compromise either joint during installation.

Also ensure enough spacing is maintained between fittings and building fabric or system components allow unhindered access for the pressing tool for correct joint completion.

If required, consider pre-fabrication of pipe & fittings as a section which can be subsequently pressed in to the system at more suitable points.

The concentricity of copper tube wall thickness in the pipework can also affect the fittings integrity

to seal when they are installed too close together, or too close to any pipe bending radii.

It is required that pipe is concentric and straight for the expected joint position and the entire minimum spacing separation distance as indicated in the table below for Brymec press fittings by size of the fitting. This distance must be applied between any fittings as a minimum from fitting edge to fitting edge. This design requirement needs to be conformant to have warranty coverage on all Brymec press fittings.

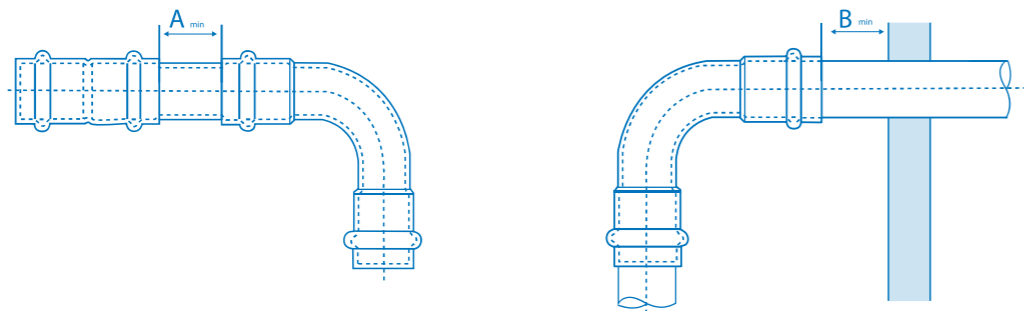

Minimum distances		
Outside pipe diameter mm	Minimum distance (mm)	
	A min	B min
15	10	60
22	10	60
28	10	60
35	20	60
42	30	60
54	40	60
67	40	60
76	40	60
108	40	60

# Spacing Requirements when Pressing

Space requirements when pressing with pressing jaws for mounting on a smooth wall, in corners and in ducts



d (mm)	A (mm)	B (mm)	C (mm)	D (mm)	E (mm)
15	20	56	20	75	131
22	20	65	31	80	150
28	25	75	31	80	150
35	30	75	31	80	170

Space requirements when pressing with pressing sling for mounting on a smooth wall, in corners and in ducts

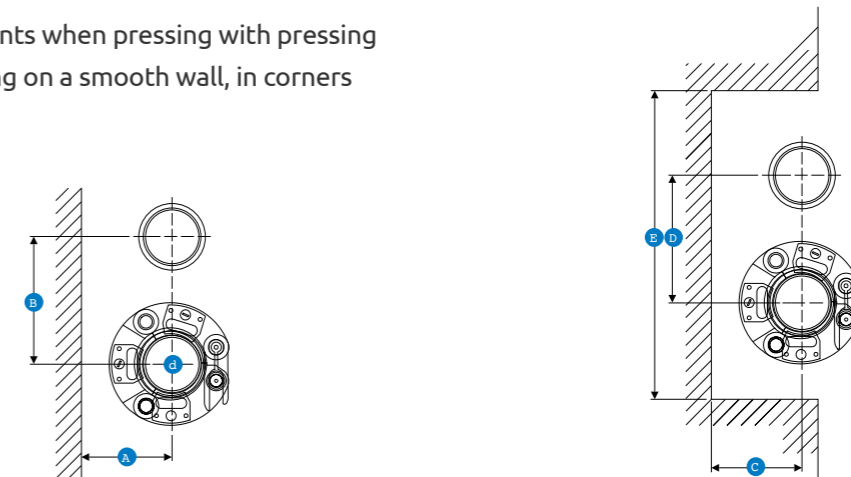

d (mm)	A (mm)	B (mm)	C (mm)	D (mm)	E (mm)
42	75	115	75	115	265
54	85	120	85	120	290
67	95	140	95	140	330
76	110	140	110	140	350
108	140	170	140	170	450

## ➤ The Pipe Clamp Spacing

Pipes must be connected directly to buildings using standard commercial clamps and may not be connected to other pipes. Clamps with a rubber lining must be used so that they cannot transfer any structure-borne sound.

The building structure needs to be able to take the weight of the pipework and the pipe supports selected must also be able to safely support the weight of the pipework and any ancillary components such as valves.

The clamp spacing is shown in the following table.

Maximum spacing of support brackets for copper tube to BS EN 1057		
Size (mm)	Horizontal Pitch	Vertical Pitch
15	1.2m	1.8m
22	1.8m	2.4m
28	1.8m	2.4m
35	2.4m	3.0m
42	2.4m	3.0m
54	2.7m	3.0m
67	3.0m	3.6m
76	3.0m	3.6m
108	3.0m	3.6m

Pipework must also be supported within 0.3 metres of a change in direction.

## ➤ Brazing near Brymec Press Fittings

No hot works, (soldering, welding or annealing) can be performed within a minimum defined distance of any installed Brymec press fitting.

The minimum separation distance by size is stated in the table below.

Considerations should be made prior to any installation that may require any soldering, welding or annealing to ensure it is done prior to installation with Brymec press fittings.

If the defined minimum separation distances cannot be achieved and any hot work detailed

needs to be performed, preventive measures need to be applied to ensure the installed fitting O-ring maximum operating temperature, defined in this document by O-ring Type, is not exceeded at any time by heat transfer or thermal conductivity.

It should also be noted that considerations also need to be taken to ensure installation location will not affect Brymec press fittings maximum operating temperature with radiant heat and/or heat transfer during installation, commissioning and operation.

Tube Size	Minimum Clearance (mm)
15mm	400
22mm	600
28mm	800
35mm	1000
42mm	1200
54mm	1500
67mm	1800
76mm	2000
108mm	2500



# Compatible Press Tools

## 15-35mm Compact Machines

Manufacturer	Press Machine	Press Jaws	Jaw Profile
Rothenberger	Romax Compact TT	Rothenberger Compact	M
REMS	Mini Press ACC	Rems Mini	M
Novopress	ACO103	NovoPress - PB1	M
Hilti	NPR 19-A/Nuron NPR 19-22	NPR PM M Jaw	M
Ridgid	RP 240/241/219	Compact Series M-Jaws	M
Klauke	MAP215	SBM	M
	MAP219	SBMX	
Milwaukee	M12 HPT	J12 Jaws	M
	M18 HPT	J18 Jaws	

## 15-54mm Standard Machines

Manufacturer	Press Machine	Press Jaws	Jaw Profile
Rothenberger	Romax 3000/4000/AC ECO	Rothenberger Standard Jaws (15-35mm)	M
		Rothenberger Standard Collars (42&54mm) + ZBS1 Adaptor	
REMS	Power-Press ACC/Akku-Press ACC/Power-Press XL ACC	REMS Standard Tongs (15-35mm)	M
		REMS Standard Press Rings (42&54mm) + Z2 Adaptor	
Novopress	ACO203/ECO203	NovoPress - PB2 Jaw (15-35mm)	M
		NovoPress - ZB202 Sling (42&54mm) + ZB203 Adaptor	
Hilti	NPR 32-A/Nuron NPR 32-22	NPR PS M Jaw (15-35mm)	M
		NPR PR M Press Ring (42&54mm) + NPR PA 2 Adaptor	
Ridgid	RP 350/351/352-XL	Ridgid Standard M-Profile Jaws (15-35mm)	M
		Ridgid Standard M-Profile Rings (42&54mm) + 69908 Actuator	
Klauke	UAP 332/432	SB Standard Jaws (15-35mm)	M
		SSK M Pressing Chain (42&54mm) + SBKQC Adaptor	
Milwaukee	M18 HPT	J18 (15-35mm)	M
		RJ18 Ring (42&54mm) + RJA-1 Adaptor	

## 67-108mm Standard Machines

Manufacturer	Press Machine	Press Jaws	Jaw Profile
REMS	Akku-Press XL	PR-3S Pressing Rings + Z7 Adaptor (Only one press on 108mm fittings)	M
		Power-Press XL ACC	
Novopress	ACO203/ECO203/ACO203XL	S330 Sling - 67-108mm + ZB221 Adaptor (108mm 1st Press)	M
		S322 Sling (Copper Only) + ZB222 (108mm 2nd Press)	
Hilti	NPR 32-A Pistol-Grip/Nuron NPR 32 XL-22	NPR PR M Press Ring (67-108mm) + NPR PA2 Adaptor (67mm)/NPR PA3 Adaptor (76&108mm 1st Press)/NPR PA4 Adaptor (108mm 2nd Press)	M
Ridgid	RP 352-XL	32 kN-XL Press Ring M (67-108mm) + 32 kN-XL Actuator. (Only one press on 108mm fittings)	M
Klauke	UAP1001120	BP HP Pressing Chain (76-108mm)	M



# Testing Procedures

The design of the Brymec Copper Press Gas fittings allows for water and/or air to pass the sealing element if a joint is unpressed. This allows unpressed joints to be identified when testing the system using the approved procedure below.

Once the fitting is pressed, the O-ring is compressed, and joint seal completed, creating a leak free permanent joint. Also the yellow coloured plastic foil ring will be destroyed during the press cycle, so pressed fittings are visibly defined from unpressed fittings.

Final testing of the system should be carried out in accordance with the latest IGEM (Institution of Gas Engineers & Managers) guidelines. There are namely three procedures that can be followed for non-domestic gas installations. These are:

- IGE/UP/1 Edition 2 – Strength testing, tightness testing and direct purging of industrial and commercial gas installations.
- IGE/UP/1A Edition 2 – Strength testing, tightness testing and direct purging of small, low pressure industrial and commercial natural gas installations.
- IGEM/UP/1B Edition 3 – Tightness testing and direct purging of small, liquefied petroleum gas/air, natural gas and liquefied petroleum gas installations.

There are two elements that are required on new installations to identify any defects in the pipework which may not have been noticed during an initial inspection of the installation.

- A strength test to identify and pipework defects which may not have been noticed during initial inspection. need to have drain valves fitted.
- A tightness test to check the integrity of the gas

pipework and that it is safe for use, or continued use, so as not to cause a hazard or unsafe situation.

The following is an overview of the guidelines and procedures for strength testing. For the full detailed procedures and methods for calculating test pressures please refer directing to IGEM. Engineers should be fully trained and certified and are responsible for the procedures used in testing.

## Strength Testing

A strength test entails pressurising the installation in excess of its normal operating pressure. The methods to calculate the strength test pressure (STP) can be obtained from IGEM. The strength test can either be pneumatic (air) or hydrostatic (water). Since the pressures used to conduct a strength test are excessive, the hydrostatic test is the safest form of test.

### Procedure for hydrostatic strength testing

- Carry out a thorough inspection of the installation.
- Open all valves within the section of pipework being tested.
- Make sure any open ends are capped off.
- Connect the water and ensure there are adequate vent points fitted to allow air to escape from the pipework.
- Connect appropriate test equipment and ensure all gauges and equipment are calibrated.
- Pressurize the pipework slowly by introducing a controlled flow of water to reach the strength test pressure.

- Once the STP has been reach the pressure needs to be maintained for the stabilisation period.
- Disconnect the pressure source and observe the pressure gauge over the full test period.
- If the gauge drops below the permitted amount, the leak needs to be identified and repaired.
- Thoroughly drain the system of water and record the test details on all relevant forms.

### Procedure for pneumatic strength testing

- Carry out a thorough inspection of the pipework being tested.
- A risk assessment must be carried out. If unacceptable risks are identified then a hydrostatic test should be carried out.
- Open all valves within the section of pipework being tested.
- Make sure any open ends are capped off.
- Connect the test medium (dry compressed air or nitrogen) to the installation.
- Install suitable regulators to the test pressure medium to ensure the strength test pressure is not exceeded.
- If the strength test pressure exceeds 1 bar then an exclusion zone should be established around the test section
- Pressurise the pipework slowly. For pressures in excess of 2 bar, raise pressure in 10% stages after 2 bar.
- Once the STP has been recached, maintain pressure for the stabilisation period.

- Disconnect the pressure source and observe the pressure gauge over the full test period.
- If the gauge drops below the permitted amount, the leak needs to be identified and repaired.
- If a tightness test is to be carried out immediately after the strength test, the pressure needs to be dropped to the operating pressure, if not vent the system of all pressure.
- Record the strength test details on all relevant forms.

## Procedure for tightness testing

To meet the requirements of UGE/UP/1 & IGE/UP/1A a tightness test needs to be carried out in the sequence below.

- Carry out a thorough inspection of the pipework being tested.
- Estimate the installation volume.
- Establish a tightness test pressure (TPP)
- Select a suitable pressure gauge for the test.
- Determine the maximum permitted leak rate (MPLR)
- Determine the tightness test duration (TDD)
- Conduct the tightness test

To make the necessary calculations required in the above, please refer to IGEM for full details.



## ▶ Purging Gas Pipework

Once the tightness test has been completed it is important that the pipework is purged to flush out any concentrations of oxygen that may be in the pipework, so that when gas is introduced it eliminates the possibility of accidental ignition.

IGEM have created a procedure which minimises the risks involved with this process. It is essential that any engineer carrying out the process is competent, qualified and fully trained.

There are two ways pipework can be purged, these are a direct or indirect purge.

- ▶ Direct Purge – this is where the pipework installation is commissioned by directly

introducing the fuel gas into the pipe. There is a risk of an air/gas mixture with this type of purge.

- ▶ Indirect Purge – this is where the pipework installation is commissioned by introducing an inert gas, typically oxygen free nitrogen, before introducing the fuel gas into the pipework. This creates a barrier between the fuel gas and the air, thus removing the risk of an air/gas mixture within the pipework.

The full testing procedures and calculations should be obtained directly from IGEM to ensure purging is done in accordance with IGE/UP/1 and IGE/UP/1/A.

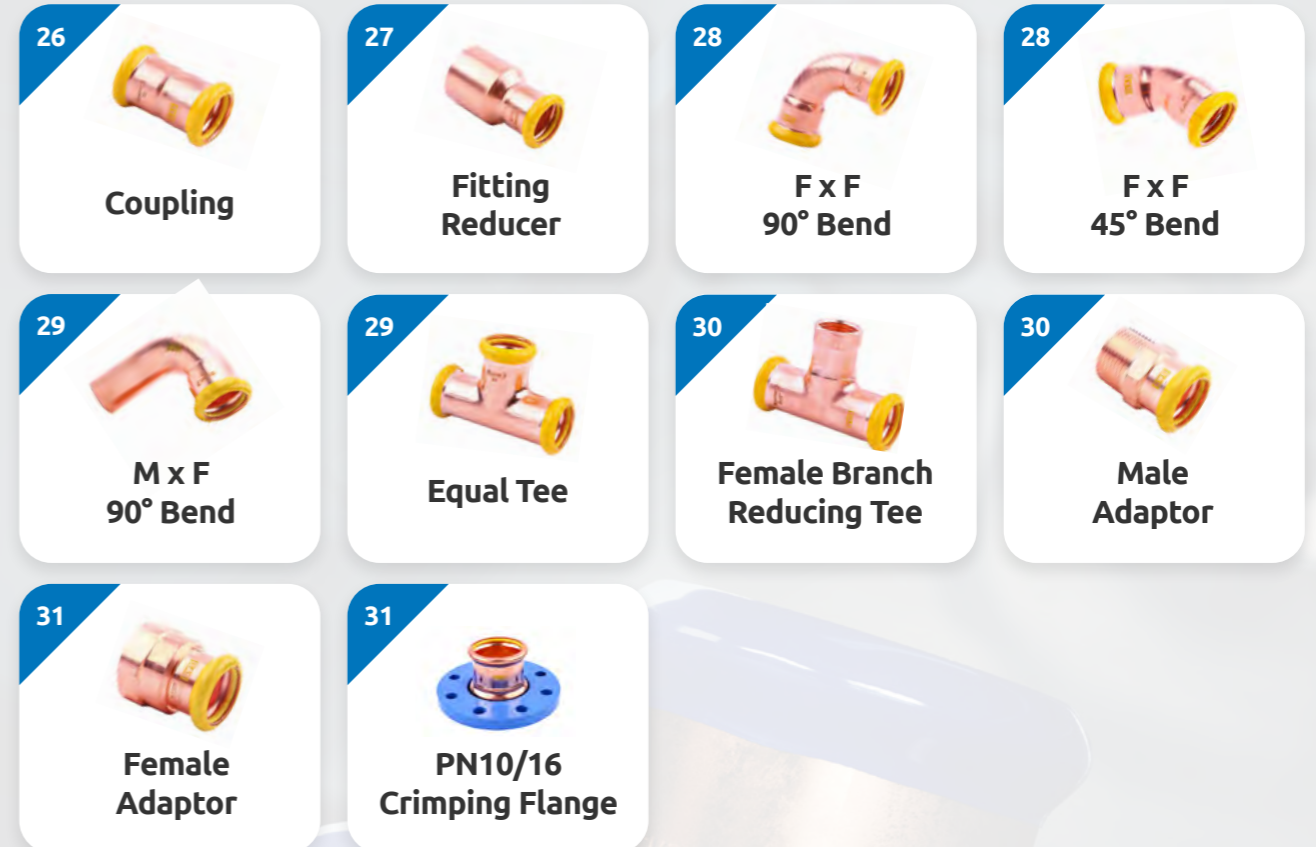

## ▶ Product Range

## ➤ Coupling

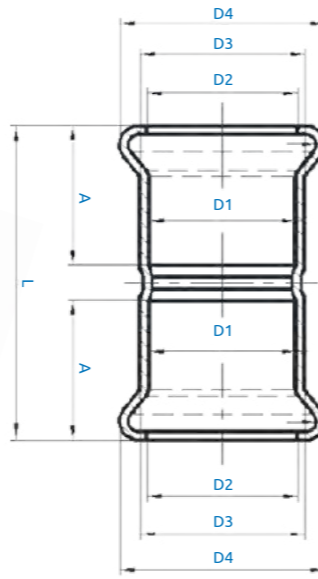

STOCK NO.	D1	D2	D3	D4	A	L
29702	15	15.6	18	23	19	44
29703	22	22.8	25	31.3	20	46
29704	28	28.8	31	37.4	22	50
29705	35	35.7	38.3	44.7	25	58
29706	42	42.8	45.3	53.5	29	67
29707	54	54.8	57.3	65.3	34	80
29708	67	69.1	71.7	82.6	48	107
29709	76	78.6	81.1	94.4	49	108
29710	108	110.9	113.8	132.1	65	147

## ➤ Fitting Reducer

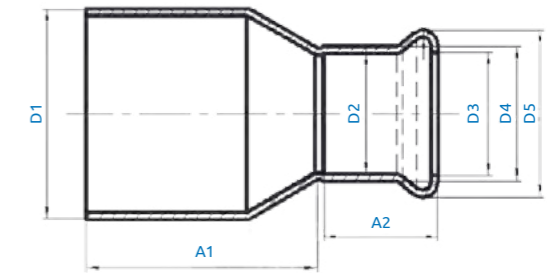

STOCK NO.	D1	D2	D3	D4	D5	A1	A2
29679	22	15	15.6	18	23	31.5	19
29680	28	15	15.6	18	23	36.5	19
29681	28	22	22.8	25	31.3	32	20
29682	35	22	22.8	25	31.3	43	20
29683	35	28	28.8	31	37.4	40	20
29684	42	22	22.8	25	31.3	49	20
29685	42	28	28.8	31	37.4	46	20
29686	42	35	35.7	38.3	44.7	44	25
29687	54	28	28.8	31	37.4	61	20
29688	54	35	35.7	38.3	44.7	58	25
29689	54	42	42.8	45.3	53.5	53	29
29692	67	42	42.8	45.3	53.5	78	29
29693	67	54	54.8	57.3	65.3	70	34
29696	76	54	54.8	57.3	65.3	76	-
29697	76	67	69.1	71.7	82.6	64	49
29699	108	54	54.8	57.3	65.3	113	-
29701	108	76	78.6	81.1	94.4	98	-



## ➤ F x F 90° Bend

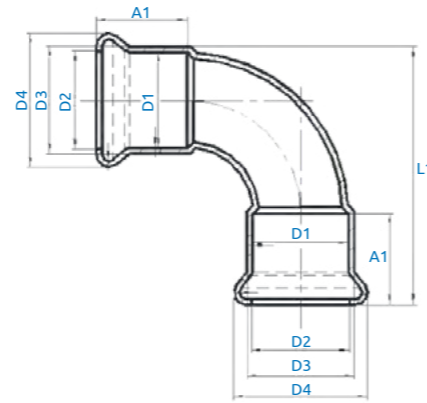

STOCK NO.	D1	D2	D3	D4	A1	L1
29609	15	15.6	18	23	19	47
29610	22	22.8	25	31.3	20	60
29611	28	28.8	31	37.4	22	73
29612	35	35.7	38.3	44.7	25	84
29613	42	42.8	45.3	53.5	29	99
29614	54	54.8	57.3	65.3	34	126
29615	67	69.1	71.7	82.6	48	163
29616	76	78.6	81.1	94.4	49	186
29617	108	110.9	113.8	132.1	65	256

## ➤ F x F 45° Bend

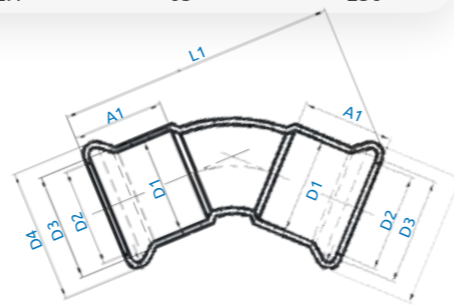

STOCK NO.	D1	D2	D3	D4	A1	L1
29627	15	15.6	18	23	19	54
29628	22	22.8	25	31.3	20	64
29629	28	28.8	31	37.4	22	74
29630	35	35.7	38.3	44.7	25	82
29631	42	42.8	45.3	53.5	29	97
29632	54	54.8	57.3	65.3	34	118
29633	67	69.1	71.7	82.6	48	169
29634	76	78.6	81.1	94.4	49	184
29635	108	110.9	113.8	132.1	65	253

## ➤ M x F 90° Bend

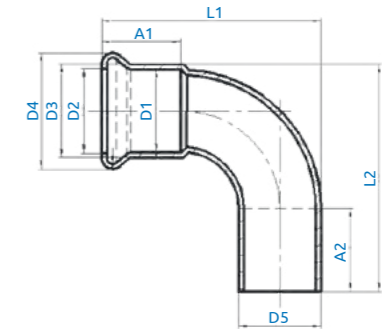

STOCK NO.	D1	D2	D3	D4	D5	A1	A2	L1	L2
29600	15	15.6	18	23	15	19	22	44.5	59
29601	22	22.8	25	31.3	22	20	23	57.5	71
29602	28	28.8	31	37.4	28	20	25	70	79.5
29603	35	35.7	38.3	44.7	35	28	25	81.5	92
29604	42	42.8	45.3	53.5	42	29	32	96	107.5
29605	54	54.8	57.3	65.3	54	34	37	123	133.5
29606	67	69.1	71.7	82.6	67	49	52	158	179
29607	76	78.6	81.1	94.4	76	49	54	184	201
29608	108	110.9	113.8	132.1	108	65	71	253	266

## ➤ Equal Tee

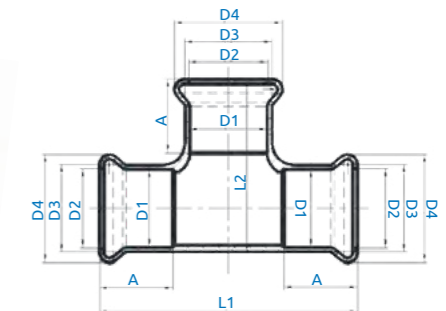

STOCK NO.	D1	D2	D3	D4	A	L1	L2
29636	15	15.6	18	23	19	64	41
29637	22	22.8	25	31.3	20	74	49.5
29638	28	28.8	31	37.4	22	84	57
29639	35	35.7	38.3	44.7	25	100	69
29640	42	42.8	45.3	53.5	29	116	86
29641	54	54.8	57.3	65.3	34	139	98
29642	67	69.1	71.7	82.6	48	189	133
29643	76	78.6	81.1	94.4	49	208	139.5
29644	108	110.9	113.8	132.1	65	273	196

## Female Branch Reducing Tee

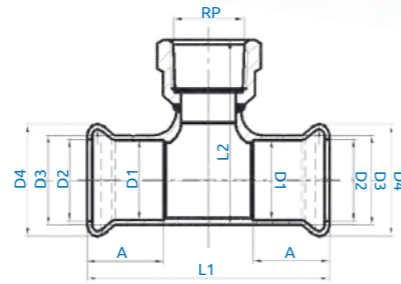

STOCK NO.	D1	D2	D3	D4	A	L1	L2	RP
29744	15	15.6	18	23	19	64	48.5	1/2"
29745	22	22.8	25	31.3	20	74	55	1/2"
29747	28	28.8	31	37.4	22	84	63	1/2"
29749	35	35.7	38.3	44.7	25	91	68	1/2"
29750	42	42.8	45.3	53.5	29	98	75	1/2"
29751	54	54.8	57.3	65.3	34	123	83	1/2"

## Male Adaptor

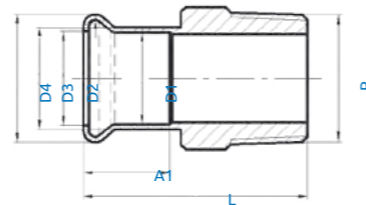

STOCK NO.	D1	D2	D3	D4	A1	L	R
29753	15	15.6	18	23	19	39	3/4"
29756	22	22.8	25	31.3	20	41	3/4"
29759	28	28.8	31	37.4	22	46	1"
29762	35	35.7	38.3	44.7	25	53	1 1/4"
29764	42	42.8	45.3	53.5	29	58	1 1/2"
29765	54	54.8	57.3	65.3	34	65	2"
29766	67	69.1	71.7	82.6	48	103	2 1/2"
29767	76	78.6	81.1	94.4	49	-	2 1/2"

## Female Adaptor

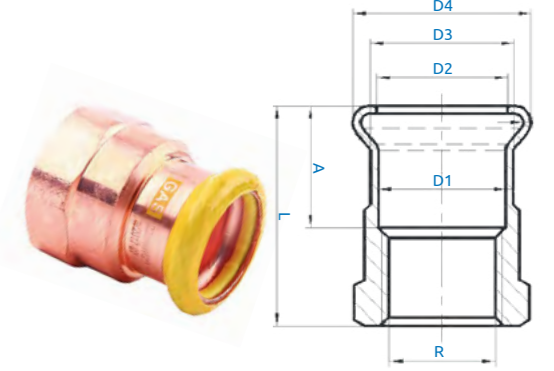

STOCK NO.	D1	D2	D3	D4	A	L	R
29771	15	15.6	18	23	19	40	1/2"
29774	22	22.8	25	31.3	20	40	3/4"
29777	28	28.8	31	37.4	22	47	1"
29780	35	35.7	38.3	44.7	25	52	1 1/4"
29782	42	42.8	45.3	53.5	29	56	1 1/2"
29783	54	54.8	57.3	65.3	34	65	2"

## PN10/16 Crimping Flange

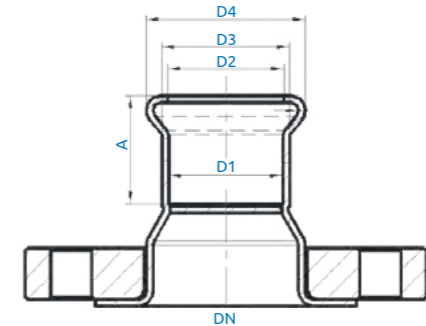

STOCK NO.	D1	D2	D3	D4	A	DN	NO. OF BOLT HOLES
29807	76	78.6	81.1	94.4	49	3"	8
29808	108	110.9	113.8	132.1	65	4"	8



# Installation Procedure



## Step 1: Cut the tube

Use an appropriate rotary copper tube cutter to ensure a clean square cut.

**Note:** It is important that the copper tube is cut completely square, the end of the tube (outside) should be clean and free from any scratches or damage such as dents or deformity.



## Step 2: Remove burrs

Make sure that the internal and external tube end is completely free from burrs or sharp edges by using a file and deburring tool.



## Step 3: Clean the tube end

Thoroughly clean the tube end using a cleaning pad in a rotating action. The tube end must be free from scratches, oxidation, dirt and debris.



## Step 4: Inspect the fitting

Before inserting the tube, remove the dust cap and check O-Rings for correct placement, that they are free of damage, dust, dirt or debris. We recommend the fittings are retained in packaging up to the point of use wherever possible.



## Step 5: Marking insertion depth on tube

All cut and deburred copper tube ends for insertion into the fitting require an insertion depth mark to be applied to the tube prior to insertion into the fitting. The mark will be applied by using a depth gauge ensuring the copper pipe fits comfortably within the right socket and using a marker pen to the required length. The mark will ensure the tube is inserted correctly into the fitting prior to press.



## Step 6: Tube insertion

The Tube should be inserted parallel into the fitting coupling ensuring no damage is caused to the 'O' ring, ensuring the insertion mark is visible at the end of the fitting next to the fitting coupling end.



## Step 7: Press tool selection

The tool to be used should be conformant, lubricated and maintained within its manufacturers service requirement. The correct jaw type and size should be selected and inspected to ensure it is clean and free from defects and contamination.

**Note:** Only approved tooling may be used on Brymec Press fittings. Refer to Approved Tooling Table on page 20 and 21.



## Step 8: Press the joint

The jaw / sling should be placed over the fitting, aligned square and positioned to ensure jaw profile will press both the shoulder and O-ring. When all requirements are correct, the tool should be activated to press the joint. The tool should complete the full cycle and the jaw ends should fully close on completion. If the tool does not complete the full cycle during operation the fitting should be cut out and replaced with new fitting. No fitting should be pressed more than once. Please ensure any other manufacturers' documented requirements are met for your respective tool.

**Note:** Only approved tooling may be used on Brymec Press fittings. Refer to Approved Tooling Table on page 20 and 21.



## Step 9: Joint completion

The fitting should be inspected after pressing to ensure the correct press has been performed and no cracking or over deforming has occurred. The pipe insertion mark should be checked and be at the fitting edge, to ensure it has not moved.

Any remains of the plastic foil ring can be removed so the fitting is left clean and visible as a completed joint.

## Insertion marking length by size

Tube Size	Marking Insertion Depth
15mm	20±3 mm
22mm	22±3 mm
28mm	23±3 mm
35mm	25±3 mm
42mm	30±3 mm
54mm	36±3 mm
67mm	47±3 mm
76mm	51±3 mm
108mm	65±3 mm

## ➤ Brymec Training Programme

As part of our commitment to providing the highest standards of installation for each project we have developed and optimised the Copper Press Training Programme

This free of charge training package ensure that every aspect of press installation is covered from start to finish. This always proved popular and enjoyable, and includes the following:

- Academy Training in our Academy Training Centre
- Or On-Site Training
- Brymec 9 Step Press Installation Training
- Practical Demonstration by experienced Installation Trainers
- Comprehensive Assessment of each Trainee
- Certification for all Trainees who successfully complete the training, valid for 3 years
- Record of all Training Certificates

We recommend wherever possible that the Training is conducted in our Academy. As well as fantastic facilities, it has the added benefits of viewing our state-of-the-art facilities and Laboratory and meeting members of the Technical Team. It also provides the opportunity to inspect other many other contributing products such as Press Fit Valves and Support and Fixing items.

If On-Site training is required that can also be supported by our experienced trainers who will be happy to share great general good practice tips in addition to specific product training.

Please contact our sales team to request this; [sales@brymec.com](mailto:sales@brymec.com)

### WHY TRAINING IS NEEDED

Key reasons for training are:

- To ensure best practice installations
- To give uniformity of quality standards
- To save speed and cost on site
- To ensure the correct tooling is selected
- To prevent errors
- To validate our 25 Year Warranty



## ➤ Brymec Technical Support

We recognise the importance of having top quality support from the manufacturer throughout every phase of the construction process, so we are here to provide assurance, technical support and assistance to safeguard your project.

Our Technical Team can assist you from Pre-construction right through to Post Contract and make sure that our attention to detail will be an asset for you.

### Key Areas of Support

#### Specification

To ensure that our products suit the application in the best possible way we can offer advice or assistance at this stage

#### BIM Models

Our products are available in BIM Objects

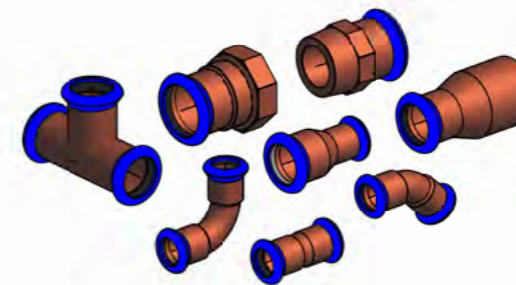

### Project Support

This includes our excellent installation training, site attendance visits, verification and testing when required. Our Technical Laboratory provides quick results from all testing and analysis.

### Post Contract

We can assist with full details for O & M Building Manuals, project information and records.

In-House Laboratory/Testing Facility

We have a purpose build laboratory to test our products to ensure they are of the utmost quality for your projects.





# ➤ Warranty On Brymec Copper Press Fittings

At Brymec we place a huge emphasis on the quality of our range of branded products. To back this up, when using the Brymec copper press system with Type TX copper tube compliant with EN 1057, Brymec will provide warranty for the same period of the copper tube being used, up to a maximum of 25 years.

This is a maximum 25-year guarantee against faults caused by defective manufacturing of Brymec copper press fittings.

For full traceability all fittings are etched or stamped with unique branding and fitting size.

## For the warranty to apply

### 1. Training

In order for the warranty to be valid each individual using the Brymec copper press system should be trained by an appropriate Brymec trainer. Upon successful completion of training, a certificate will be issued.

To arrange training please call **0333 000 55 55** or email [sales@brymec.com](mailto:sales@brymec.com)

### 2. Tooling

Approved tools within manufacturer's service requirements, that are well maintained and used as per manufacturer's detailed requirements.

### 3. Tube

Tube must be Type TX conformant to EN 1057.

### 4. Environment

Brymec press must be installed in a suitable environment and be used for the correct application.

### 5. Installation

All Brymec press fittings to be installed in accordance with the Brymec press installation guidelines, and BS EN 806. All commissioning paperwork must be retained, including for extension / addition to any previously tested part of the system.

To view the full warranty terms and conditions visit [brymec.com/warranty](http://brymec.com/warranty)





# Terms of Business

## 1. BACKGROUND

**1.1** These Terms apply to the Contract between Brymec and the Customer for the sale of Brymec Products. Any other terms, whether implied by custom or practice, or which the Customer may seek to include, are specifically excluded.

**1.2** Capitalised words (such as 'Contract'), have a specific meaning which is set out in 10 below.

## 2. CONTRACT TO BUY PRODUCTS

**2.1** The Products are described on Brymec's website and in its catalogue. Specifications for Products are subject to change, in which case, Brymec will endeavour to supply an equivalent or suitable alternative.

**2.2** When the Customer wishes to place an order for Products, it will provide a purchase order to Brymec. If Brymec accepts such order, it will issue an Order Acceptance to the Customer, at which point the Contract shall come into existence.

**2.3** The Customer is responsible for ensuring that the details in the Order Acceptance are complete and accurate.

## 3. DELIVERY

**3.1** Each delivery of the Products will be accompanied by a delivery note that shows the date of the Order Acceptance, the relevant Brymec reference number, and the type and quantity of the Products.

**3.2** Brymec shall deliver the Products to the Delivery Location at any time after Brymec notifies the Customer that the Products are ready.

**3.3** Delivery is completed on the completion of unloading of the Products at the Delivery Location (and, if applicable, Signed For.)

**3.4** Customer must notify any issues of non-delivery, discrepancy or damage to Brymec within 2 business days of Delivery (see further 4.2 below).

**3.5** Any dates quoted for delivery are approximate only, and the time of delivery is not of the essence. Brymec shall use all reasonable commercial efforts to meet any specific delivery dates. However, Brymec will not be liable for any delay in delivery of the Products.

**3.6** If Brymec fails or is unable to deliver the Products for any reason (except for an Unforeseen Event), its liability shall be limited to the costs and expenses incurred by the Customer in obtaining replacement Products of similar description and quality in the cheapest market available, less the price of the Products. Brymec shall have no liability for any failure to deliver the Products to the extent that such failure is caused

by an Unforeseen Event, or the Customer's failure to provide Brymec with adequate delivery instructions or any other instructions that are relevant to the supply of the Products.

**3.7** Brymec may deliver the Products by instalments, which shall be invoiced and paid for separately. Any delay in delivery or defect in an instalment shall not entitle the Customer to cancel any other instalment.

## 4. QUALITY

**4.1** Brymec warrants that, on delivery, the Products shall conform in all material respects with their description and any applicable Specification. For products sold by weight, or in the manufacturer's packaging, Brymec may supply quantities of up to 5% more or less than the amount ordered.

**4.2** Subject to 4.3 and 4.4 below, if i) the Customer gives notice in writing to Brymec within 2 business days of delivery that the Products do not comply with the Specification, and ii) Brymec is given a reasonable opportunity to examine such Products, and iii) the Customer returns such Products to Brymec's place of business at the Customer's cost, Brymec shall, at its option, replace the defective Products or refund the price of the defective Products in full.

**4.3** Brymec shall not be liable for the Products' failure to comply with the warranty set out in clause 4.1 if: i) the Customer makes any further use of such Products after giving notice under 4.2 above; ii) the defect arises because the Customer failed to follow good trade practice or instructions as to the storage, commissioning, installation or use of the Products; or iii) the Customer alters or attempts to repair such Products.

**4.4** Brymec may accept Product returned to it no later than 10 business days after the date of Delivery for credit or exchange, provided that the correct delivery details are provided. In this case, Brymec may make a charge for handling and restocking equal to 25% of the price of the returned Products.

**4.5** Non-stock Products purchased by Brymec at the Customer's request are non-returnable and non-refundable.

**4.6** Other than as set out above, Brymec shall have no liability to the Customer in respect of the Products' failure to comply with the warranty set out in clause 4.1.

## 5. TITLE AND RISK

**5.1** The risk in the Products shall pass to the Customer on completion of delivery.

**5.2** Title to the Products shall not pass to the Customer until the earlier of: i) Brymec receives payment in full for the Products; and ii) the Customer resells the Products, in which

case title to the Products shall pass to the Customer at the time specified in 5.4 below.

**5.3** Until title to the Products has passed to the Customer, the Customer shall store the Products separately from all other products held by the Customer so that they remain readily identifiable as Brymec's property, maintain the Products in satisfactory condition, and keep them insured against all risks for their full price from the date of delivery.

**5.4** The Customer may use or resell the Products before Brymec receives payment for the Products, in which case it does so as principal and not as Brymec's agent, and title to the Products shall pass from Brymec to the Customer immediately before the time at which such reuse or resale by the Customer occurs.

## 6. PRICE AND PAYMENT

**6.1** The price of the Products shall be the price set out in the Order Acceptance issued by Brymec. Brymec may, by giving notice to the Customer at any time up to delivery, increase the price of the Products to reflect any increase in the cost of the Products that is due to i) any factor beyond Brymec's control (including foreign exchange fluctuations, increases in taxes and duties, and increases in labour, materials and other manufacturing costs), or ii) any request by the Customer to change the delivery date(s), quantities or types of Products ordered, or the Specification.

**6.2** The price of the Products excludes amounts in respect of value added tax (VAT), which the Customer shall additionally be liable to pay.

**6.3** Unless otherwise stated on the Order Acceptance, Brymec shall be responsible for the cost of insurance and transport of the Products to the Delivery Location.

**6.4** Brymec may invoice the Customer for the Products on or at any time after the Products have been despatched.

**6.5** Unless otherwise stated in the Order Acceptance, the Customer shall pay the invoice in full and in cleared funds by the end of the month following the month the invoice was dated to the bank account nominated by Brymec. Time for payment is of the essence.

**6.6** The Customer must raise any invoice queries with Brymec by email to [creditcontrol@brymec.com](mailto:creditcontrol@brymec.com) within 28 days of the invoice date. Brymec will endeavour to respond within 2 business days and to propose a resolution to the Customer within 3 working days. The Customer must communicate any non-acceptance of such resolution to Brymec within 3 business days, failing which the relevant invoice remains payable according to these Terms.

**6.7** If the Customer fails to make any payment due to Brymec under the Contract by the due date for payment, then Brymec

shall be entitled to charge interest on the overdue amount at the rate of 4.0% per annum above the base rate from time to time of the Bank of England. Such interest shall accrue on a daily basis from the due date until actual payment of the overdue amount, whether before or after judgment. The Customer shall pay the interest together with the overdue amount.

**6.8** The Customer shall pay all amounts due under the Contract in full without any set-off, counterclaim or deduction. Brymec may set off any amount owing to it by the Customer against any amount payable by Brymec to the Customer.

## 7. LIMITATION OF LIABILITY AND INSURANCE

**7.1** Nothing in these Terms shall limit or exclude Brymec's liability for: (i) death or personal injury caused by its negligence; ii) fraud or fraudulent misrepresentation; iii) breach of the terms implied by section 12 of the Sale of Goods Act 1979; or defective products under the Consumer Protection Act 1987.

**7.2** Subject to 7.1 above, Brymec shall under no circumstances whatsoever be liable to the Customer, whether in contract, tort (including negligence), breach of statutory duty, or otherwise, for any loss of profit, or any indirect or consequential loss arising under or in connection with the Contract; and

**7.3** Brymec has obtained insurance cover in respect of its own legal liability for individual claims not exceeding £1,000,000 per claim. Therefore Brymec's total liability to the Customer in respect of all other losses arising under or in connection with the Contract, whether in contract, tort (including negligence), breach of statutory duty, or otherwise, shall in no circumstances exceed £1,000,000, and the Customer is responsible for making its own arrangements for the insurance of any excess loss.

## 8. UNFORESEEN EVENTS

**8.1** Neither party shall be in breach of this Contract nor liable for delay in performing, or failure to perform, any of its obligations under this Contract if such delay or failure results from an Unforeseen Event. If the period of delay or non-performance continues for three months, the party not affected may terminate this Contract by giving one month's written notice to the affected party.

## 9. GENERAL

**9.1** Assignment. The Customer may not assign, transfer, mortgage, charge, subcontract or deal in any other manner with any or all of its rights or obligations under the Contract without Brymec's prior written consent.

**9.2** Confidentiality. Each party undertakes that it shall not at any time during this agreement, and for a period of 5 years after termination of this agreement, disclose to any person any confidential information concerning the business, affairs,



customers, clients or suppliers of the other party, except as permitted by this paragraph. Each party may disclose the other party's confidential information: (i) to its employees, officers, representatives or advisers who need to know such information for the purposes of carrying out its obligations under or in connection with the Contract; and (ii) as may be required by law. No party shall use any other party's confidential information for any purpose other than to exercise its rights and perform its obligations under or in connection with this agreement.

**9.3 Entire agreement.** This Contract constitutes the entire agreement between the parties and supersedes and extinguishes all previous agreements and understandings between them, whether written or oral, relating to its subject matter. Each party agrees that it shall have no remedies in respect of any statement, representation, assurance or warranty (whether made innocently or negligently) that is not set out in this agreement.

**9.4 Variation.** No variation of this Contract shall be effective unless it is in writing and signed by the parties (or their authorised representatives).

**9.5 Third party rights.** No one other than a party to this Contract shall have any right to enforce any of its terms.

**9.6 Law and jurisdiction.** The Contract, and any dispute or claim arising out of or in connection with it shall be governed by and construed in accordance with the law of England and Wales. Each party agrees that the courts of England and Wales shall have exclusive jurisdiction to settle any dispute or claim arising out of or in connection with this Contract.

## 10. DEFINITIONS:

**10.1 Brymec:** Brymec Limited, whose registered office is at Unit C, Redlands, Coulsdon, Surrey, CR5 2HT.

**10.2 Terms:** the terms set out in this document.

**10.3 Contract:** the contract between Brymec and the Customer for the sale and purchase of the Products in accordance with these Terms.

**10.4 Customer:** the business or person who purchases the Products from Brymec.

**10.5 Delivery Location:** the location for delivery of the Products set out in the Order Acceptance, or such other location as the parties may agree.

**10.6 Order Acceptance:** a form issued by Brymec in response to a Customer's order for Products, specifying Product details, quantities, prices and costs of transportation.

**10.7 Products:** the products (or any part of them) set out in the Order Acceptance.

**10.8 Signed For:** a Customer requirement stated in the Order Acceptance that a delivery of Product must be signed for at the Delivery Location.

**10.9 Specification:** any specification for the Products set out on Brymec's website or in its catalogue.

**10.10 Unforeseen Event:** an event or circumstance beyond a party's reasonable control.

# Quality Policy

**Brymec Ltd (the 'Organisation') aims to provide defect free products and services to its customer on time and within budget.**

The Organisation operates a Quality Management System that has gained BS EN ISO 9001 : 2015 certification, including aspects specific to the stockholding and supply of mechanical, plumbing and air conditioning products and services.

This gives us a platform to guarantee a structured approach to our continuous improvement cycle, and ensure we continue to meet and exceed the following key goals:

- Excellence of service to our customers, delivering on site, in full, on time; in the relentless pursuit of total customer satisfaction.
- Offering quality products and systems. We work with worldwide manufacturing plants (in line with our social and ethical policy) to source the best products for the UK market. We ensure that the products are fit for purpose and comply with the relevant approvals and standards. We also research and develop innovative solutions which will add value to our customers, developers and end users
- To motivate, engage and continuously develop our team by providing training, coaching, knowledge sharing and investment to ensure their absolute competence.
- To continue to invest in technology, working to understand customers' needs and streamline their buying processes to maximise efficiencies via modern technology.

This quality policy is endorsed and regularly reviewed by our Senior Management Team, and its scope is communicated to all Brymec employees via our website and other appropriate methods.

Our vision is to become an essential and indispensable supplier to the Building Services Contractor by providing excellence of service, quality products and continually investing in technology.

In order to achieve our vision, we ensure Brymec is an organisation where people love to work, upholding our core values of excellence, courage and collaboration to actively engage our team in contributing towards providing the highest level of customer satisfaction.

**Luke Reiner**

Managing Director





***Brymec*** 

[www.brymec.com](http://www.brymec.com)

0333 000 55 55