

Copper Press 45° M x F Bend (M-Profile)



MCP 13



Technical Data

- Working Pressure 16 Bar @ 95°C
- "M" profile press jaws or slings
- Approved tools include Novapress, REMS, Rothenberger and Ridgid

Applicable Standards

- WRAS approved
- For use with type TX copper tubing conformant to EN 1057
- Manufactured to EN1254 standard



Features & Benefits

- Durable and secure leak proof joint
- Braze free, permanent joint - no hot works required
- Huge time and resource savings
- 25 Year warranty
- Blue plastic film which will fall off when crimped for easy identification of pressed joint
- 2 point press
- Dust Covers

Material Specifications

NO	Description	Materials
1	Body	Cu-DHP (CW024A)
2	Crimp indicator film	PVC, Blue
3	O-Ring	EPDM
4	Dust Cap	PE

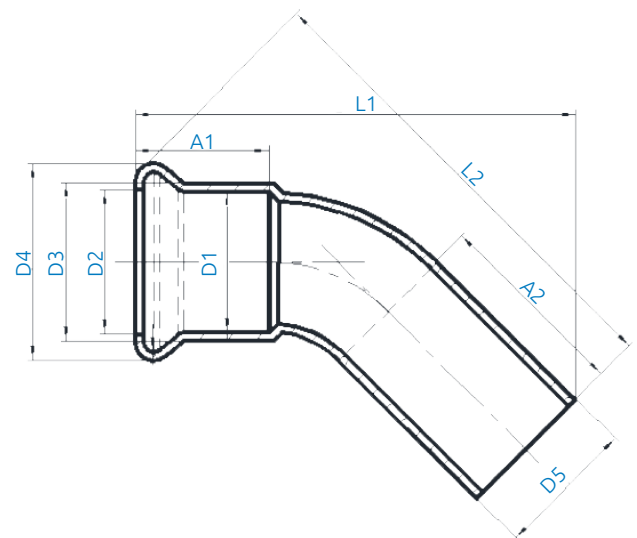

Product Codes and Dimensions

STOCK NO.	D1	D2	D3	D4	D5	A1	A2	L1	L2
27820	15	15.6	18	23	15	19	22	57.5	62
27821	22	22.8	25	31.3	22	20	23	69.5	74.5
27822	28	28.8	31	37.4	28	20	25	80	86
27823	35	35.7	38.3	44.7	35	28	25	86	90.5
27824	42	42.8	45.3	53.5	42	29	32	103	109
27825	54	54.8	57.3	65.3	54	34	37	123	129
27826	67	69.1	71.7	82.6	67	49	52	177	178
27827	76	78.6	81.1	94.4	76	49	52	184	193
27829	108	110.9	113.8	132.1	108	65	68	253	267