

Cast Iron Swing Check Valve

CIV4 

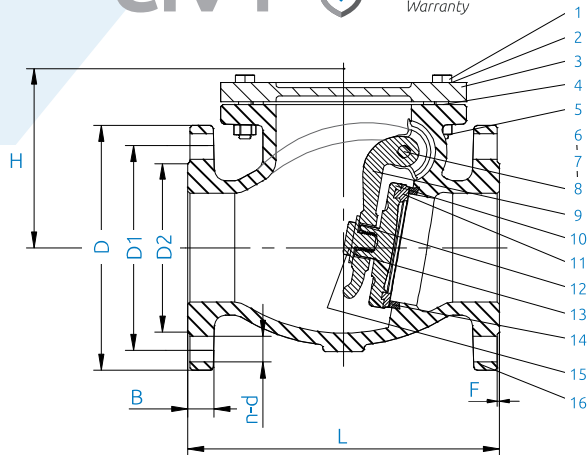

NO.	PART	MATERIAL	ENGLISH STANDARD
1	Bolts	Steel	BS970 43A
2	Gasket	Graphite	
3	Bonnet	Cast Iron	
4	Body Gasket	Graphite	BS2494 Typew
5	Nuts	Steel	BS970 43A
6	Side Plug	Brass	BS2874 CZ122
7	Gasket	Fiber	
8	Hanger Pin	Stainless Steel	BS970 304S15
9	Hanger	Cast Iron	
10	Disc	Cast Iron	
11	Disc Ring	Cast Bronze	
12	Washer	Steel	BS970 43A
13	Split Pin	Stainless Steel	BS970 43A
14	Seat Rings	Cast Bronze	
15	Nut	Steel	BS970 43A
16	Body	Cast Iron	

Features and Benefits

- Removable cover for easy maintenance
- Internal and external epoxy coating
- Full bore for low headloss
- Cast bronze seal and disk ring

Applicable Standards

- Face-to-face: BS 5153
- Flange: EN 1092 ISO 7005
- Testing: EN 12266

Technical Data

- Operating Temperature Range: -10°C to +100 °C
- Operating Pressure: 16 bar
- Field Of Operation: Water

Pressure / Temperature Chart

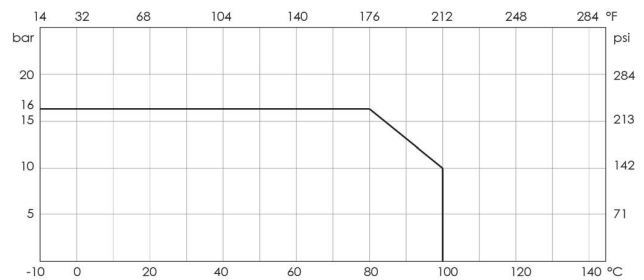

Product Codes & Dimensions

STOCK NO.	SIZE	DN	L	D	D1	D2	B	F	N-D	H	Weight (Kg)
38791	2"	50	203	165	125	99	20	3	4-19	112	13.3
38968	2 1/2"	65	216	185	145	118	20	3	4-19	132	15.77
38969	3"	80	241	200	160	132	22	3	8-19	141	20
38970	4"	100	292	220	180	156	24	3	8-19	162	29.37
38971	5"	125	330	250	210	184	26	3	8-19	192	42
38972	6"	150	356	285	240	211	26	3	8-23	211	53.5
38792	8"	200	495	340	295	266	30	3	12-23	270	102
38793	10"	250	622	405	355	319	32	3	12-28	316	149
38794	12"	300	699	460	410	370	32	4	12-28	357	182