

Cast Iron Dual Plate Wafer Check Valve

CIV8 



Features and Benefits

- Self acting pivot check valve with double disc.
- Corrosion resistant springs.
- Automatically opens when the flow starts.
- Elastomer seats are vulcanised and bonded to body casting.

Applicable Standards

- Design standards: GB/T12236
- End standard: suitable for EN1092-2 PN16
- Face to face standard: ISO 5752
- Testing standard: ISO 5208

Material Specifications

NO	NAME	MATERIAL	QUANTITY
1	Plug	SS304	4
2	Washer	PTFE	2
3	Pin	SS410	2
4	Washer	PTFE	3
5	Spring	SS304	2
6	Plate	CF8M	2
7	Body	CI	1
8	Eyeblot	SS304	1
9	Trademark	Stainless Steel	1
10	Plate Rivet	Stainless Steel	2
11	Seat	EPDM	1

Technical Data

- Size: DN50 - DN300 (2" - 12")
- Max Pressure: PN16
- Temperature Range: -20°C - 135°C
- Suitable for: Water

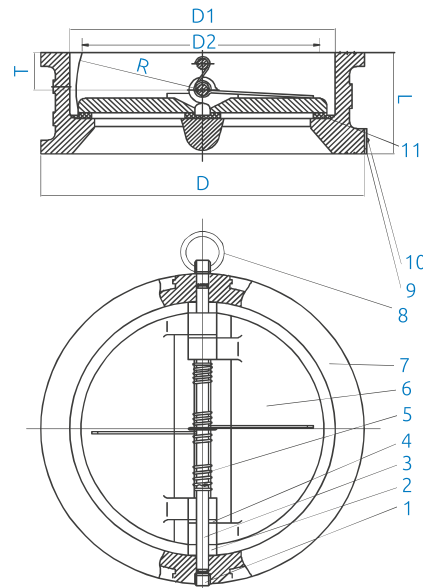

Product Codes & Dimensions

STOCK NO.	SIZE	D	D1	D2	L	R	T	Weight (Kg)
38923	DN50	106	65	45.6	43	29.7	18.5	1.5
38924	DN65	126	78	60.1	46	36.1	21.5	2.4
38925	DN80	141	94	66.3	64	43.4	28	3.6
38926	DN100	161	117	97.2	64	55.6	27	5.7
38927	DN125	191	145	122.4	70	68.1	30	7.3
38928	DN150	217	170	144.4	76	78.6	31	9
38855	DN200	272	222	198.0	89	104.4	33	17
38862	DN250	327	265	233.7	114	128	50.5	26
38883	DN300	380	310	283.2	114	148	43	42