

Data sheet

Actuators for three point control AMV 110 NL, AMV 120 NL

Description



The actuators are used together with automatically balanced combination valve type AB-QM for DN 10 to DN 32.

Typical applications for that products are: temperature control and permanent automatic balancing on terminal units (fan-coils, chilled ceilings, air-handling units..).

Main data:

- Gap detection at stem up position
- 3 point version
- Force switch-off at stem down position prevents overload of actuator and valve
- No tools required for mounting
- Maintenance-free lifetime
- Low-noise operation
- Halogen free cables

Ordering

Actuators

Type	Supply voltage (V)	Speed (s/mm)	Cable length (m)	Code No,	
				Single Pack	Industry Pack
AMV 110 NL	24 AC	24	1,5	082H8056	/
			5,0	082H8080	082H8076
			10	082H8090	082H8086
AMV 120 NL		12	1,5	082H8058	/
			5,0	/	082H8078
			10	/	082H8088

Note:

Actuators with 5 m and 10 m cable length are produced on request. Please note this increases lead time.

Spare parts

Type	Length (m)	Code No.
Cable (24 V)	5	082H8052
	10	082H8054

Technical data

Type			AMV 110 NL	AMV 120 NL
Power supply		V	24 AC, +10 to -15 %	
Power consumption	running	VA	1	
	standby	W	0	
Frequency		Hz	50 Hz/60 Hz	
Close of force		N	130	
Stroke		mm	5	
Speed		s/ mm	24	12
Relative humidity			max. 80 %	
Max. medium temperature	°C		120	
Ambient temperature			0 ... 55	
Storage and transport temperature			-40 ... 70	
Protection class			II	
Grade of enclosure			IP 42	
Weight		kg	0,3	
- marking in accordance with standards			Low Voltage Directive (LVD) 2006/95/EC: EN 60730-1, EN 60730-2-14 EMC Directive 2004/108/EC: EN 61000-6-2, EN 61000-6-3	

Installation

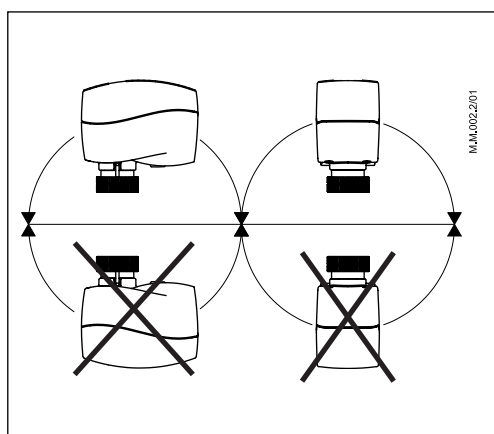

Mechanical

The actuator should be mounted with the valve stem in either horizontal position or pointing upwards.

The actuator is fixed to the valve body by means of a mounting ring, which requires no tools for mounting. The ring should be tightened by hand.

Electrical

Important: It is strongly recommended that the mechanical installation is completed before the electrical installation.

Each actuator is supplied with the connecting cable for the controller.

Wiring

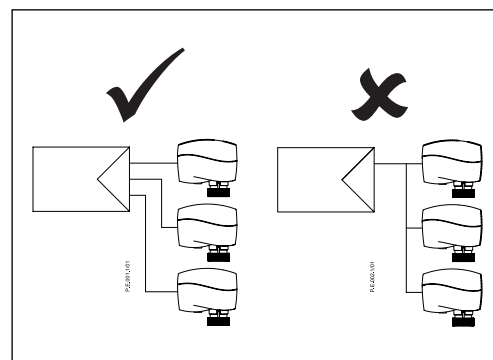
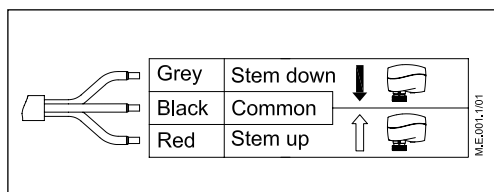

Installation and commissioning procedure
(if required)



Do not touch anything on the PCB!
Do not remove the cover before the power supply is fully switched off.

1. Check the valve neck. The actuator should be in stem up position (factory setting). Ensure that the actuator is mounted securely on the valve body
2. Wire the actuator according to the wiring diagram
3. The direction of the stem movement can be observed on the position indicator

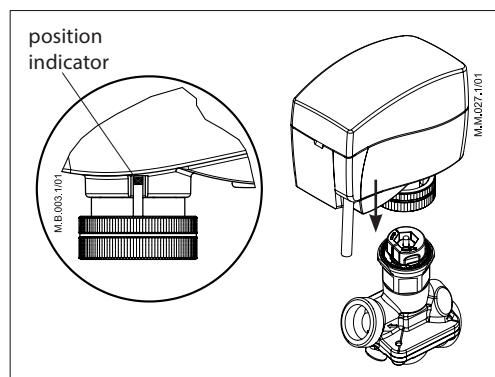

Manual override
(for service purposes only)



Caution:
Do not manually operate the drive if power is connected!

Do not dismantle the actuator from the valve when it is in a stem down position!
If dismantled in a stem down position, there is a high risk that the actuator gets stuck.

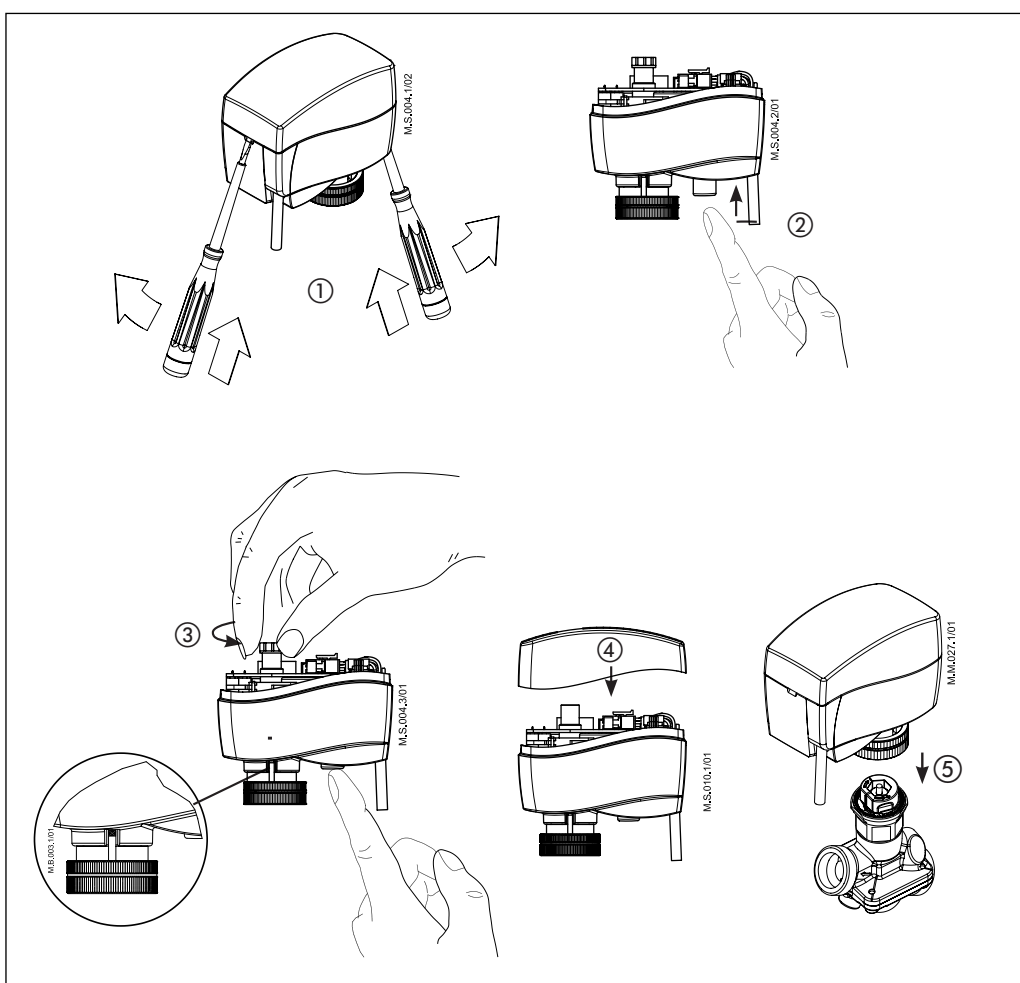

- Remove cover ①
- Press and hold the button ② (on the bottom side of the actuator) during manual override ③
- Replace cover ④
- Install actuator on valve ⑤

Remark:
A 'click' sound after energising the actuator indicates that the gear wheel has jumped into normal position.

Commissioning

The factory setting of the spindle is the fully stem up position because of easier mechanical connection of the actuator on the valve.

Dimensions (mm)

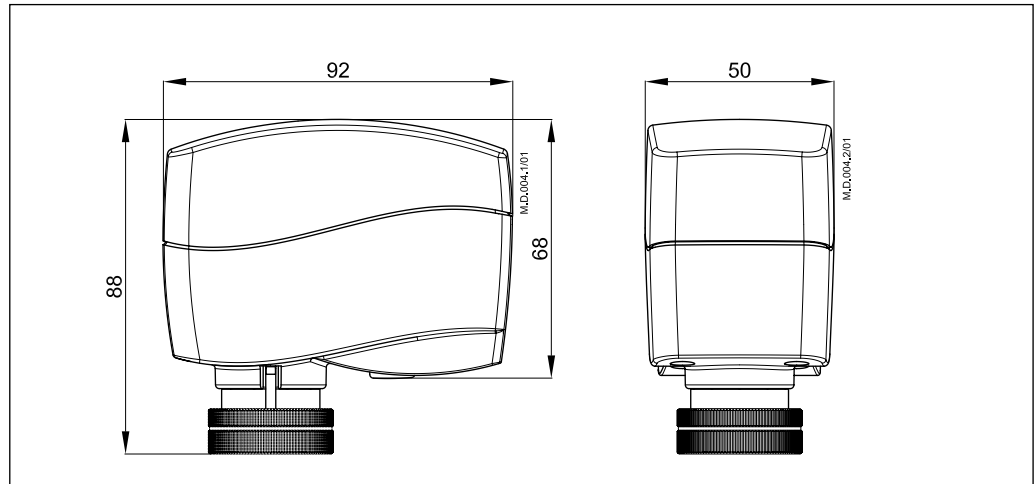

Danfoss A/S

Climate Solutions • danfoss.com • +45 7488 2222

Any information, including, but not limited to information on selection of product, its application or use, product design, weight, dimensions, capacity or any other technical data in product manuals, catalogues descriptions, advertisements, etc. and whether made available in writing, orally, electronically, online or via download, shall be considered informative, and is only binding if and to the extent, explicit reference is made in a quotation or order confirmation. Danfoss cannot accept any responsibility for possible errors in catalogues, brochures, videos and other material. Danfoss reserves the right to alter its products without notice. This also applies to products ordered but not delivered provided that such alterations can be made without changes to form, fit or function of the product.

All trademarks in this material are property of Danfoss A/S or Danfoss group companies. Danfoss and the Danfoss logo are trademarks of Danfoss A/S. All rights reserved.