

Brass Automatic Air Vent with Check Valve

AVE2



Features and Benefits

- Automatic air venting during operation
- Suitable for heating/cooling or sanitary
- Can discharge large quantities of air
- Check valve allows service and maintenance without draining system

Technical Data

- Fields of Applications: Water & glycol solutions
- Max. Working Pressure: PN10
- Max. working temperature: 110°C

Applicable Standards

- Male thread connection are to: ISO 228

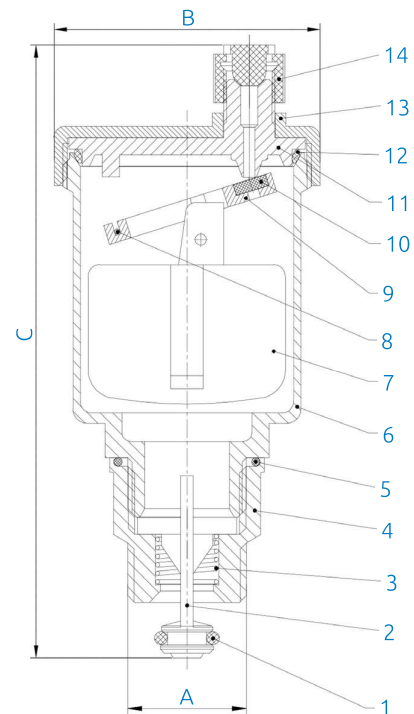

Product Codes & Dimensions

STOCK NO.	WRAS	SIZE	A	B	C
36257	Yes	15mm	3/8"	48	106
30849	No	1/2"	1/2"	47	107

Material Specifications

NO	NAME	MATERIAL	QUANTITY
1	O-ring	EPDM	1
2	Plastic Bar	PP	1
3	Spring	SS302	1
4	Connection Nut	HPb59-T	1
5	O-ring	EPDM	1
6	Body	HPb59-T	1
7	Balance Weight	PP	1
8	Tension Spring	SS302	1
9	Plastic Plate	POM	1
10	Rubber Gasket	EPDM	1
11	Cover	POM	1
12	O-ring	EPDM	1
13	Pressure Cover	HPb59-T	1
14	Plastic Cap	POM	1