

# Copper Press GAS M x F 90° Bend (M-Profile)



## MGP 12



### Technical Data

- Max Working Pressure 5 Bar (External) / 1 Bar (Internal) @ 70°C
- "M" profile press jaws or slings
- Approved tools include Novapress, REMS, Rothenberger and Ridgid
- Suitable for above ground 2nd and 3rd family gases to EN437

### Applicable Standards

- For use with type TX copper tubing conformant to EN 1057



### Features & Benefits

- Durable and secure leak proof joint
- Braze free, permanent joint - no hot works required
- Huge time and resource savings
- 25 Year warranty
- Yellow plastic film which will fall off when crimped for easy identification of pressed joint
- 2 point press
- Dust covers keep O-ring clean prior to assembly

### Material Specifications

NO	Description	Materials
1	Body	Cu-DHP (CW024A)
2	Crimp indicator film	PVC, Ochre Yellow
3	O-Ring	HNBR
4	Dust Cap	PE

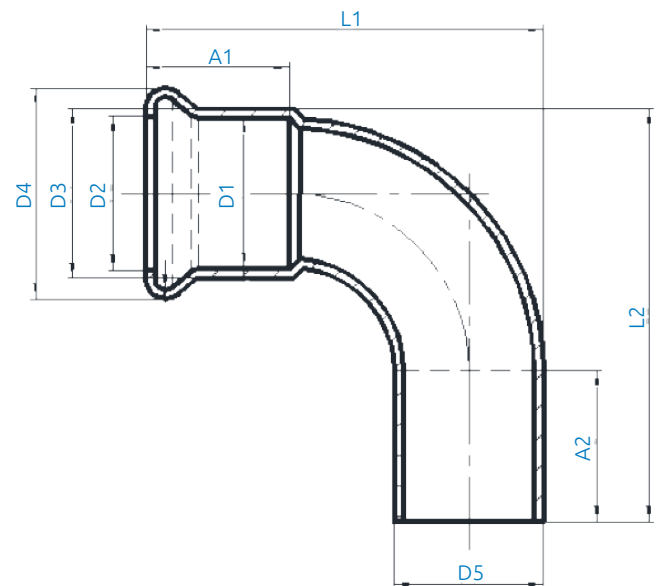

### Product Codes and Dimensions

STOCK NO.	D1 (mm)	D2 (mm)	D3 (mm)	D4 (mm)	D5 (mm)	A1 (mm)	A2 (mm)	L1 (mm)	L2 (mm)
29607	76	78.6	81.1	94.4	76	49	54	184	201
29608	108	110.9	113.8	132.1	108	65	71	253	266