

Water Meter Carrier

Product Code: 30946

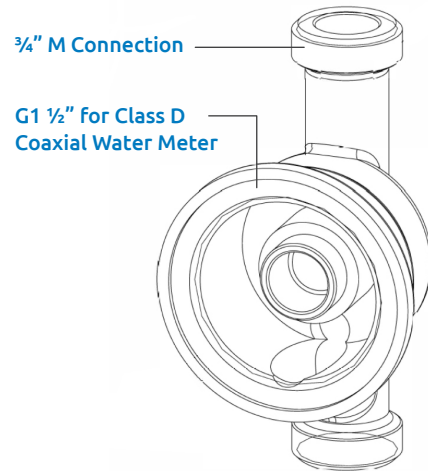

Features & Benefits

- For use with class D coaxial water meters
- Easy to install, either horizontally or vertically
- Dust cap on water meter carrier protects from contamination during installation
- Dust cap only to be removed following system flushing and treatments.
- WRAS approved

Technical Data

- Medium: DCW / Potable water
- Min. working pressure: 1 bar
- Max. working pressure: PN16
- Recommended velocity range for avoidance of noise: 1-2 m/s
- Working temperature range: 5 - 85°C
- Connections: 3/4" BSP
- Water meter carrier connection: DN40 internal thread (screw)
- Supplied as part of water meter assembly - item 30967

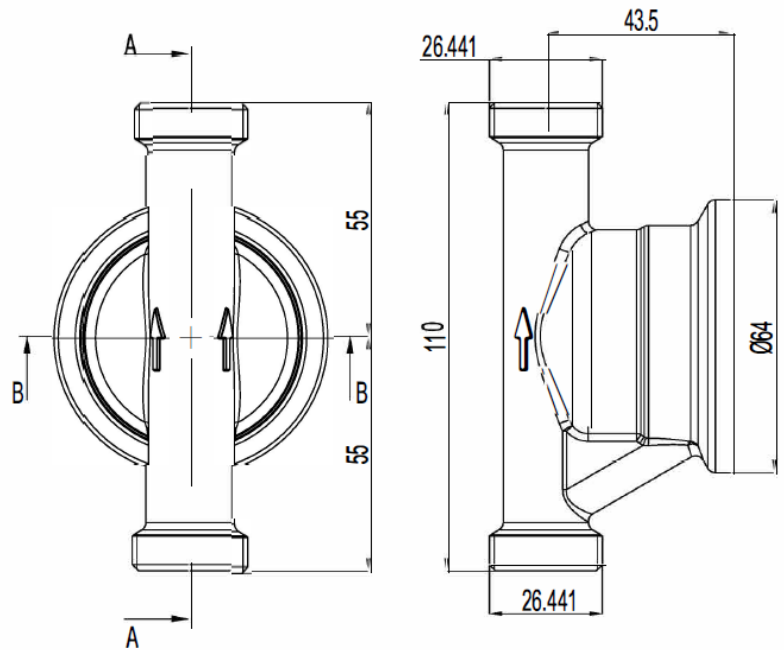

Material Specifications

No.	Description	Materials
1	Body	Brass CW602N
2	Water Carrier Cap	Plastic - Technyl A



Scan or click to order online.