

# Stainless Press Crimping Flange PN10

## MSP71

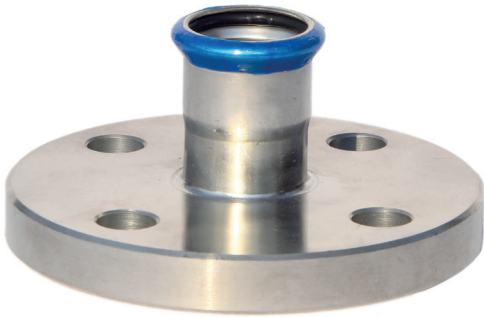

### Technical Data

- Operating temperature -20°C ~ +120°C
- 316L Stainless Steel fitting
- EPDM Sealing ring
- "M" Profile Press Jaws or slings
- Approved tools include Novapress, REMS, Rothenberger and Ridgid
- Max Working Pressure
  - 15 – 28mm : 40 bar
  - 35 – 54mm : 25 bar
  - 76 – 108mm : 16 bar

### Features and Benefits

- Suitable for Potable water, Cooling systems, Industrial applications
- High grade Stainless Steel is extremely durable and corrosion resistant
- Blue plastic film which will fall off when crimped for easy identification of pressed joint
- Dust covers
- 30 Year Warranty

### Applicable Standards

- WRAS Approved
- 316L grade stainless steel fitting
- DVGW-W534

### Material Specifications

Description	Materials
Body	316L Stainless Steel
Crimp indicator film	PVC, Blue
O-Ring	EPDM
Dust Cap	PE

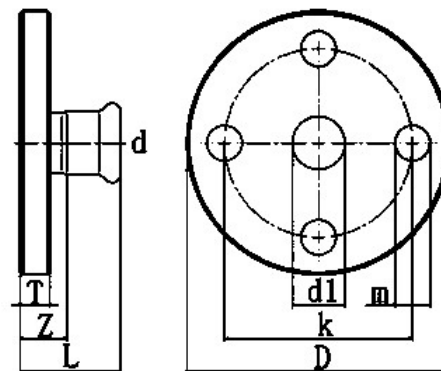

### Product Codes and Dimensions

STOCK NO	d (Pipe Diameter - mm)	D (mm)	k (mm)	L (mm)	T (mm)	m (mm)	d1 (mm)	Z (mm)
29548	15	95	65	43	11	14	12	23
29549	22	105	75	47	12	14	20	26
29550	28	115	85	54	14	14	25	31
29551	35	140	100	62	15	18	32	36
29552	42	150	110	70	16	18	40	40
29553	54	165	125	84	18	18	50	49
29554	76	185	145	129	18	18	65	76
29555	89	200	160	148	20	18	80	88
29556	108	220	180	173	20	18	100	98