

# Brass Gate Valve with Lockshield - Compression

## GVA1LS



### Features and Benefits

- Compression ends
- Brass body & Gate (wedge)

### Applicable Standards

- Valves are manufactured to: BS5154
- Compression connections comply with: EN1254-2
- WRAS approved

### Technical Data

- Suitable for: Water
- Max. Working Pressure: PN16
- Max. Working Temp: 90°C

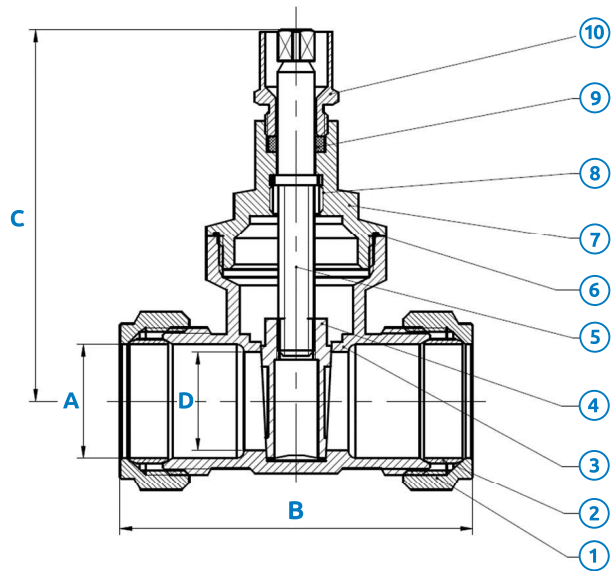

### Product Codes and Dimensions

STOCK NO	A (mm)	B (mm)	C (mm)	D (mm)
30700	15	54	57	13
30707	22	65	80	15
30299	28	72	91	19
30793	35	90	112	32

### Material Specifications

NO	NAME	MATERIAL	QUANTITY
1	ComperSSION nut	HPb59- T	2
2	Olive	T2	2
3	Body	HPb59- T	1
4	Gate	HPb59- T	1
5	Stem	HPb59- T	1
6	Sealing washer	PTFE	1
7	Bonnet	HPb59- T	1
8	Lock ring	HPb59- T	1
9	Packing	PTFE	1
10	Lock nut	HPb59- T	1