

2. DATOS DE INSTALACION

2.1 AB-SF

Hose clamp



Coating



Zinc plated

Base Materials



Flexible Piping



Plastic Piping

Installation data

Code	ØD (mm)	ØD (")	A x B (mm)	L	Torque (Nm)	Characteristics
ASF008016	8 ÷ 16	5/16 ÷ 5/8	9 x 0,70	23	4,50	<ul style="list-style-type: none"> • For piping from Ø8 to Ø150 mm. • Surface finish: Zinc plated ≥ 5 microns. • Washer screw, to facilitate screw torque. • Steel profile, 0.7 to 0.8 mm thick, depending on measurement. • Especially suitable for hoses, plastic piping, industrial use, etc. • Quick and easy to install.
ASF12022	12 ÷ 22	1/2 ÷ 7/8	9 x 0,70	23	4,50	
ASF16027	16 ÷ 27	5/8 ÷ 1 1/16	9 x 0,70	26	4,50	
ASF20032	20 ÷ 32	3/4 ÷ 1 1/4	9 x 0,70	26	4,50	
ASF25040	25 ÷ 40	1 ÷ 1 5/8	9 x 0,70	26	4,50	
ASF30045	30 ÷ 45	1 3/16 ÷ 1 3/4	9 x 0,80	26	4,50	
ASF35050	35 ÷ 50	1 3/8 ÷ 2	9 x 0,80	26	4,50	
ASF40060	40 ÷ 60	1 5/8 ÷ 2 3/8	9 x 0,80	26	4,50	
ASF50070	50 ÷ 70	2 ÷ 2 3/4	9 x 0,80	26	4,50	
ASF60080	60 ÷ 80	2 3/8 ÷ 3 1/8	9 x 0,80	26	4,50	
ASF70090	70 ÷ 90	2 3/4 ÷ 3 1/2	9 x 0,80	26	4,50	
ASF80100	80 ÷ 100	3 1/8 ÷ 4	9 x 0,80	26	4,50	
ASF90110	90 ÷ 110	3 1/2 ÷ 4 3/8	9 x 0,80	26	4,50	
ASF100120	100 ÷ 120	4 ÷ 4 3/4	9 x 0,80	26	4,50	
ASF110130	110 ÷ 130	4 3/8 ÷ 5 1/8	9 x 0,80	26	4,50	
ASF120140	120 ÷ 140	4 3/4 ÷ 5 1/2	9 x 0,80	26	4,50	
ASF130150	130 ÷ 150	5 1/8 ÷ 5 7/8	9 x 0,80	26	4,50	

DRAWING

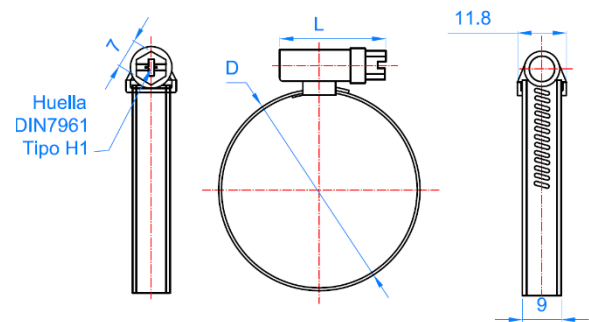

APPLICATION EXAMPLES

