



WATER MEASUREMENT



## SMART+

### SINGLE-JET DRY WATER METERS JS-02



Smart+ is a single-jet dry water meter intended to measurement of flow and quantity of cold water of the temperature up to 30°C or hot water of the temperature up to 90°C. Thank to modern construction is adapted to the assembly of RF frontend, which enables remote readings of indication and also it is the best protected dry water meter against activity of strong magnetic field. The construction of the water meter gives the possibility of its assembly both as in a horizontal position with the counter directed upward (H) and in a vertical position with the counter directed aside (V). Thank to the use of a rotary counter enabling easy readings. It perfectly proves itself in different assembly positions.



Protection against external mechanical interference into the counting mechanism, which was obtained by the use of a seal on the clamp terminal and by a strengthened construction of counter housing.



A rotation blockade of the counting mechanism by the rotation by the angle more than 360 °C.

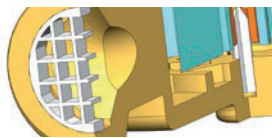

Strainer on the water meter's inlet which builds the protection against penetrating the measuring body by dirt.

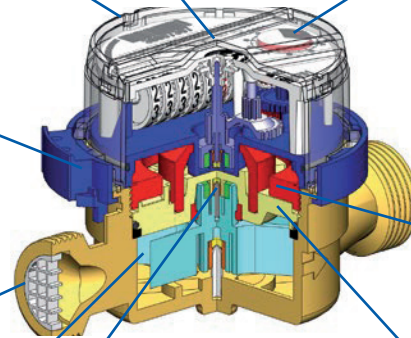

A hermetic counter (with increased tightness) resistant to fogging.

Total resistance of the data transmission system against the influence of external magnetic field obtained by the application of pointer with a reflection as an optical element of data transfer from the water meter to the RF frontend.

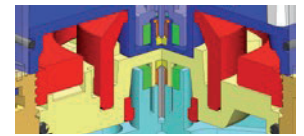

Very high resistance of the water meter Smart to the influence of the external magnetic field SN+, resulting from application of special magnetic screen and of 4-pole magnet of a magnetic clutch.



Very high resistance to rapture of the magnetic clutch, obtained by suitable distance between frontal surfaces of the magnetic clutch.

Protection limiting the results of water freezing in form of a special formed sealing plate.

Mutually bearing rotor (by the application of high quality pins and bearing stones) provides exploitation in the time between legalizations, with retaining the normative legalization parameters.

### KEY ADVANTAGES OF THE WATER METER SMART+

- Resistance to strong, external magnetic field – currently the best protected dry water meter against influence of the external magnetic field on the market. The resistance to the influence of the external magnetic field is above the requirements of the norm PN-EN 14154.
- Remote readings – water meter adapted to the assembly of the RF front end for the communication in standards like Wireless M-Bus or pulse communication without interference into the water meter both as during the first installation and as the operation.
- Possibility of alarm signalling – a water meter with RF front end has the possibility of signalling e.g. dismantling or rapture of the front end, work interferences of the front end, retrograde flow, leakage, etc.
- Metrological properties – fulfilment of newest metrological requirements MID.
- Indication reliability by:
  - division of the water meter into the wet part with measuring body and the dry part with counting mechanism,
  - solid and tested and simultaneously permanently improved construction,
  - high service life.
- Easily reading by:
  - hermetic counting resistant to fogging,
  - legible digits on the barrels in two colours, enabling the accurate reading,
  - counter rotation within 360°C.
- Protection against mechanical external interference – by the strengthened construction of the counting mechanism housing.

Technical parameters

Parameter			JS 1,6-02 JS90 1,6-02*	JS 2,5-02 JS90 2,5-02*	JS 2,5-G1-02 JS90 2,5-G1-02*	JS 4-02 JS90 4-02*	
Nominal diameter	DN	mm	15		20		
Continuous flow rate	$Q_3$	m <sup>3</sup> /h	1,6	2,5		4	
Max flow rate	$Q_4$	m <sup>3</sup> /h	2	3,125		5	
Indirect flow rate	for cold water	H R100	$Q_2$	dm <sup>3</sup> /h	25,6	40	64
		V R50			51,2	80	128
	for hot water	H R80 or R100**			32 or 25,6**	50 or 40**	80 or 64**
		V R40 or R50**			64 or 51,2**	100 or 80**	160 or 128**
Minimum flow rate	for cold water	H R100	$Q_1$	dm <sup>3</sup> /h	16	25	40
		V R50			32	50	80
	for hot water	H R80 or R100**			20 or 16**	31,25 or 25**	50 or 40**
		V R40 or R50**			40 or 32**	62,5 or 50**	100 or 80**
Starting flow	-	dm <sup>3</sup> /h	6	8		15	
Ratio $Q_3/Q_1$	-	-	1,6				
Temperature class (nominal working temperature)	-	-	T30 / T90				
Resistance classes to flow profiles	-	-	U0, D0				
Indication range	-	m <sup>3</sup>	10 <sup>5</sup>				
Indication correctness	-	m <sup>3</sup>	0,00005				
Max pressure	$P_{max}$	MPa	1,6				
Max pressure loss for $Q_3$	$\Delta p$	kPa	63				
Permissible boundary error at the range: $Q_2 \leq Q \leq Q_4$	$\epsilon$	%	± 2 for cold water ± 3 for hot water				
Permissible boundary error at the range: $Q_1 \leq Q \leq Q_2$	$\epsilon$	%	± 5				
Connector thread	G	cal	G $\frac{3}{4}$		G1		
Height	H	mm	68,5				
Length	L	mm	110	110	130	130	
Diameter	D	mm	72				
Mass (without connection elements)	-	kg	0,5	0,5	0,6	0,6	

Realization 02 – eight-barrel counter, water meter adapted to the assembly of the RF frontend  
 \*) Available also in version 02-S - with hard bearing (water meters for hot water circulation system).  
 \*\*) On request

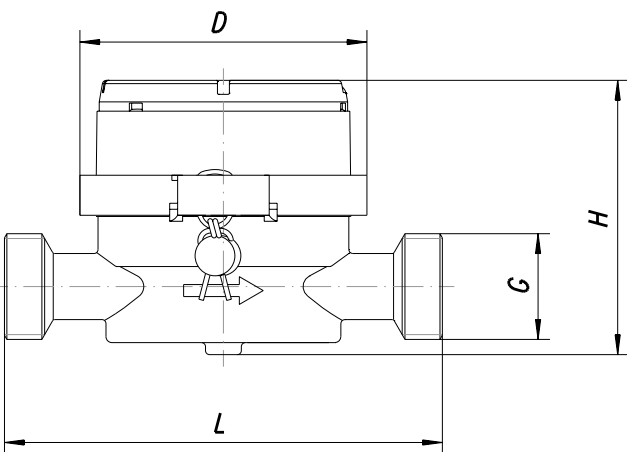

Pressure loss

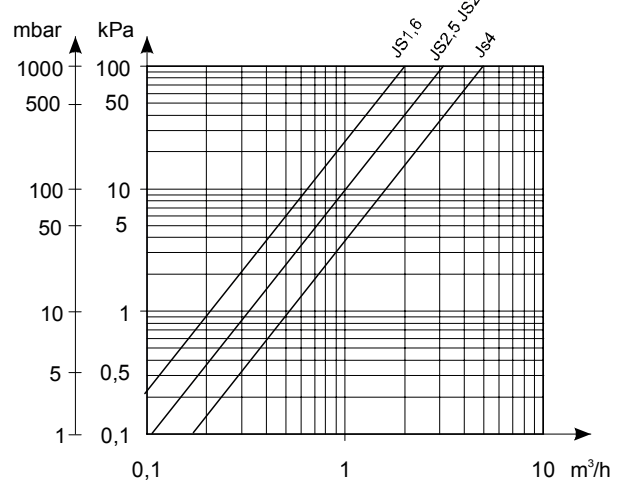

Connection elements

DN	G	g	d	L
	inch	inch	mm	mm
15	3/4	1/2	17	40
20	1	3/4	23	50

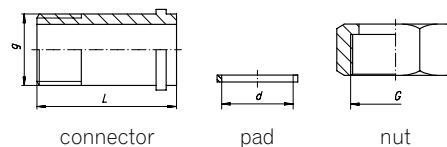



## REMOTE INDICATION READING



### SMART + JS-02

#### Water meter smart + (02)

eight-barrel water meter for cold and hot water adapted to the assembly of the RF frontend SMART TOP enabling remote indication reading.

### COMPATIBILITY WITH NORMS AND REGULATIONS

- Directive 2004/22/EC of The European Parliament and the Council of Europe dated on March, 31st, 2004 regarding measuring instrument,
- PN-EN-14154 :2005 – water meters, part 1 ÷3,
- OIML R49:2004 and 2006 – water meters intended to measurement of cold drinking water and of hot water
- certificate of analysis, type WE – cold water number SK09-MI001-SMU007, hot water number SK09-MI001-SMU009, hot water R100 number TCM 142/11-4832.

All materials used during the production of the water meter Smart have proper Hygienic Clearance allowing the product to contact with the drinking water.

#### Example of order:

Water meter for i.e.:

- cold water – water meter JS 2,5-02
- hot water – water meter JS90 2,5-02

#### As additional order we also provide:

- connector for the water meter, without valve,
- connector for the water meter, with valve (preventing the indication retreat of the water meter by forced water circuit in the opposed direction),
- disposable clamps with plastic snap seals, with unique numeration (protecting the mechanical manipulation by the water meter's connectors).